

Inhoudsopgave

Drijfwerkhuis 01	21
Kappen 04	7
Koppeling 03	15
Schakelpoken 04	51
Stickers 01	65
Stuur & Kabels 04	43
Stuurboom 03	33
Tandwielen 01	25
Type Stickers 02	61
Wielas 02	29
Wielen & Banden 03	53
Parts Index	67

Code	Description	Notes
001_2_12649	001_02 - BODYGUARD	Version: MF 510, MF 530, MF 520, MF 500
001_3_12676	001_03 - BODYGUARD	
001_4_12698	001_04 - BODYGUARD	
002_0_12722	002_00 - SELF-VENTILATING CONE CLUTCH	
002_1_12741	002_01 - SELF-VENTILATING CONE CLUTCH	
002_2_12761	002_02 - SELF-VENTILATING CONE CLUTCH	
002_3_12779	002_03 - SELF-VENTILATING CONE CLUTCH	
02A_0_13875	CLUTCH (510)	
03A_0_13890	GEARBOX (510)	
03A_1_13913	GEARBOX (510-515-515L-515S)	
04A_0_14000	GEARS (510)	
04A_1_14034	GEARS (510 -515)	
005_1_13022	005_01 - WHEEL AXLE	
005_2_13039	005_02 - WHEEL AXLE	
007_2_13157	007_02 - STEERING COLUMN	Version: MF 530, MF 520, MF 500
007_3_13177	007_03 - STEERING COLUMN (500/10/20/30-530S/S2)	
008_2_13308	008_02 - HANDLEBAR	
008_3_13362	008_03 - HANDLEBAR (500-510-520-530)	
008_4_13416	008_04 - HANDLEBAR (500-510-520-530)	
009_2_13534	009_02 - CONTROLS (500-510-520-530)	Version: MF 510, MF 530, MF 520, MF 500
009_3_13564	009_03 - CONTROLS(500/10/20/30-530S/S2)	
009_4_13594	009_04 - CONTROLS(500/10/20-530-530S2)	
011_3_13744	W011_03 - HEELS	
012_0_13785	012_00 - STICKERS	
012_1_13807	012_01 - STICKERS	
012_2_13824	012_02 - STICKERS	
013_0_13845	013_00 - STICKERS	
013_1_13860	013_01 - STICKERS	

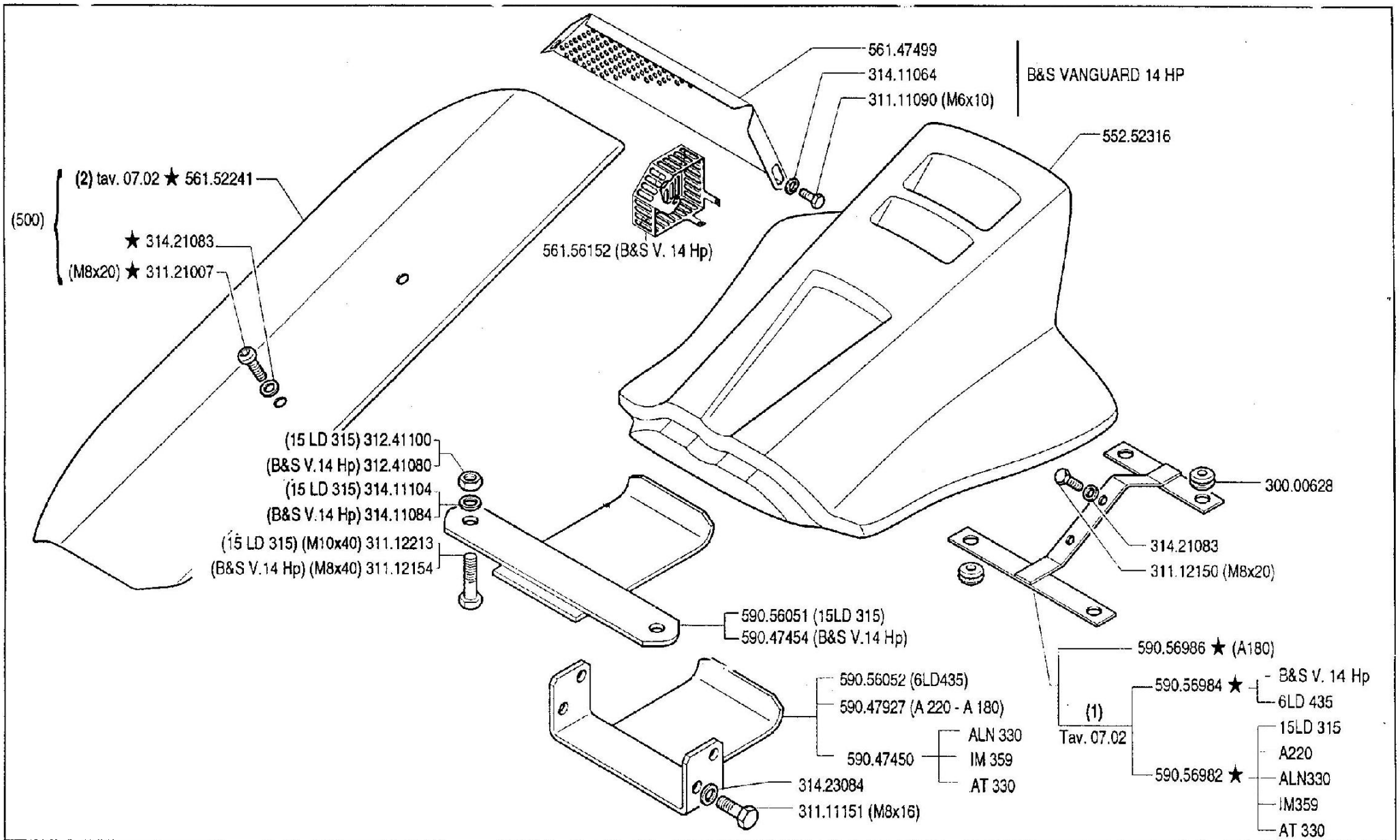

B&S VANGUARD 14 HP

	500 serie 95	CARROZZERIA (500 - 510 - 520 - 530)		DALLA MACCHINA DE LA MAQUINA DE LA MACHINE FROM THE MACHINE AB DER MASCHINE	22690 (530)	01.02
	CARROCERIA CARROSSERIE	BODY KAROSSERIE	158933 (520)			
			★ (510)		9/1997	
			★ N. 80952 (500)			

Pos.	Code	Q.ty	Description	Notes
30000628	30000628	0	CABLE GLAND 90/200/30	
31111090	31111090	0	SCREW TE M5X10 UNI 5739 8G	
31111151	31111151	0	SCREW TE M8X16 UNI 5739 8G	
31112150	31112150	0	SCREW TE M8X20 UNI 5739 8G	
31112154	31112154	0	SCREW TE M8X40 UNI 5739 8G	
31112213	31112213	0	SCREW TE M10X40 UNI 5739	
31121007	31121007	0	SCREW BCEI M8X20 ISO7380	
31241080	31241080	0	HEXAGON SELFLOCK NUT M8	
31241100	31241100	0	SELFLOCK HEXAGON NUT M10	
31411064	31411064	0	WASHER 6,4x12,5	
31411084	31411084	0	WASHER 8,4x17	
31411104	31411104	0	WASHER 10,5x18	
31421083	31421083	0	WASHER	
31423084	31423084	0	SPRING WASHER 8,4	
55252316	55252316	0	BODYWORK	
56147499	56147499	0	GUARD	
56152241	56152241	0	CARROZZERIA MF LAT./97 *V*	
56156152	56156152	0	GUARD	
59047450	59047450	0	SHIELD	
59047454	59047454	0	SHIELD	
59047927	59047927	0	SHIELD	
59056051	59056051	0	SHIELD	
59056052	59056052	0	SHIELD	
59056982	59056982	0	HOLDER	
59056984	59056984	0	HOLDER	
59056986	59056986	0	HOLDER	

500

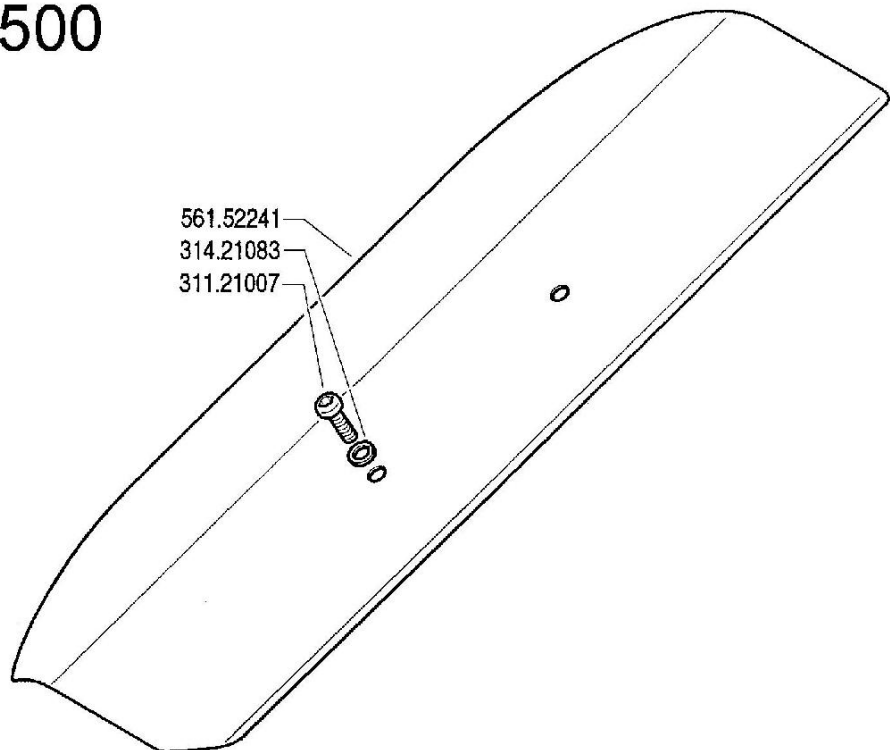

510 - 520 - 530

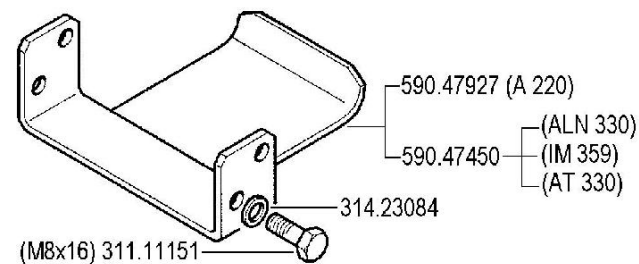
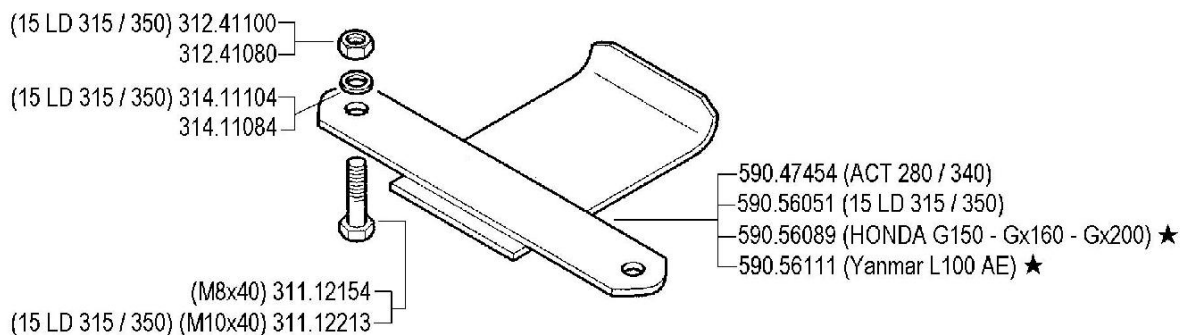
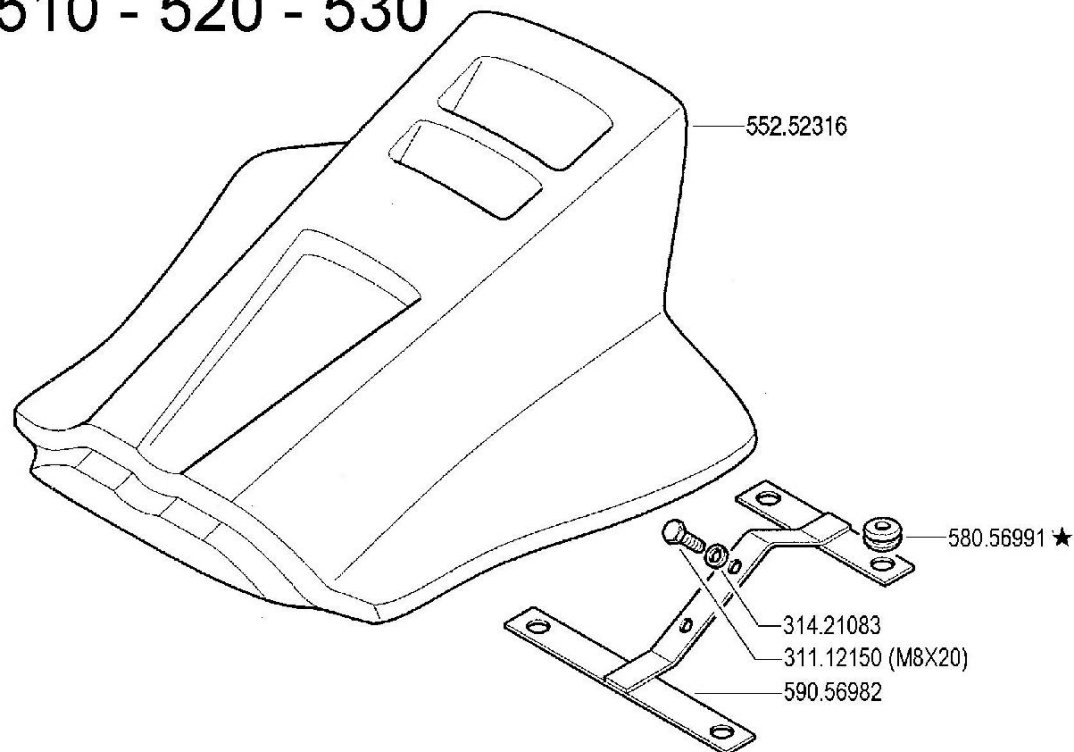

FERRARI

500 serie 95

BODY
CARROCERIA

CARROZZERIA

CARROSSERIE
KAROSSERIE

DALLA MACCHINA
DE LA MAQUINA
DE LA MACHINE
FROM THE MACHINE
AB DER MASCHINE

AGGIORNAMENTO

REVISION

MISE A JOUR

APLAZAMIENTO

ANPASSUNG

01 03

1/2000

★N.

Mod.

ZENIT

Pos.	Code	Q.ty	Description	Notes
31111151	31111151	0	SCREW TE M8X16 UNI 5739 8G	
31112150	31112150	0	SCREW TE M8X20 UNI 5739 8G	
31112154	31112154	0	SCREW TE M8X40 UNI 5739 8G	
31112213	31112213	0	SCREW TE M10X40 UNI 5739	
31121007	31121007	0	SCREW BCEI M8X20 ISO7380	
31241080	31241080	0	HEXAGON SELFLOCK NUT M8	
31241100	31241100	0	SELFLOCK HEXAGON NUT M10	
31411084	31411084	0	WASHER 8,4x17	
31411104	31411104	0	WASHER 10,5x18	
31421083	31421083	0	WASHER	
31423084	31423084	0	SPRING WASHER 8,4	
55252316	55252316	0	BODYWORK	
56152241	56152241	0	CARROZZERIA MF LAT./97 *V*	
58056991	58056991	0	CABLE GLAND	
59047450	59047450	0	SHIELD	
59047454	59047454	0	SHIELD	
59047927	59047927	0	SHIELD	
59056051	59056051	0	SHIELD	
59056089	59056089	0	SHIELD	
59056111	59056111	0	SHIELD	
59056982	59056982	0	HOLDER	

500

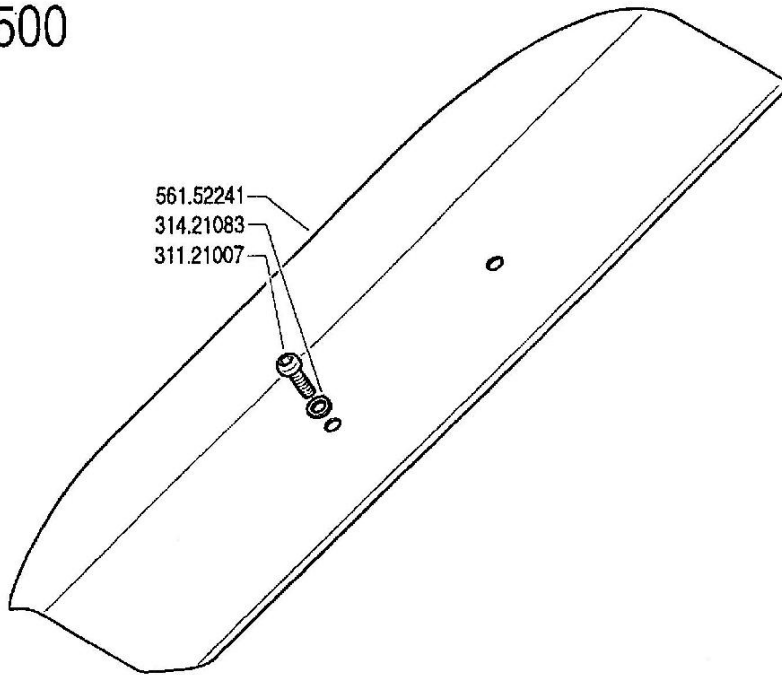

510 - 520 - 530 - 530S ★ - 530S2 ★

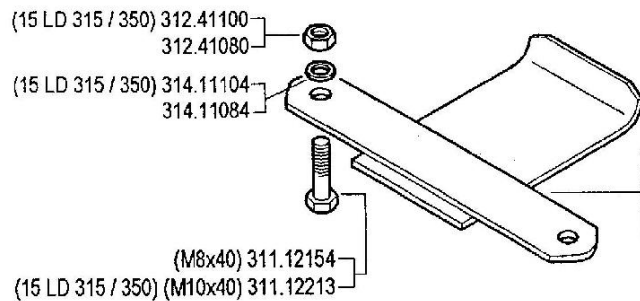
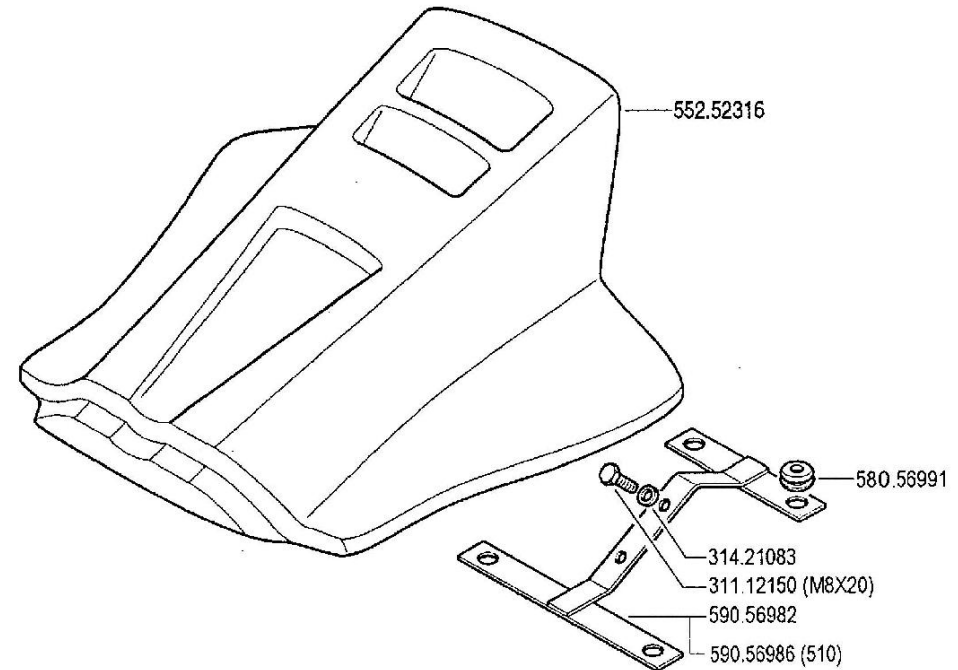

- 561.56119 ★ (ACT 280 / 340)
- 590.56051 (15 LD 315 / 350)
- 590.56089 (HONDA Gx120 ★ - Gx160 - Gx200)
- 590.56111 (Yanmar L100 AE)

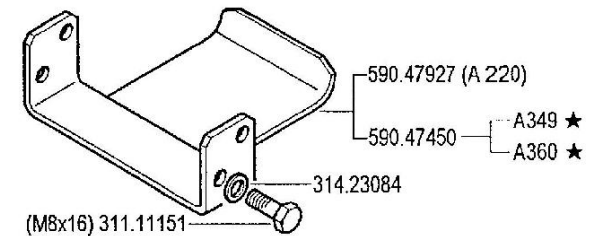
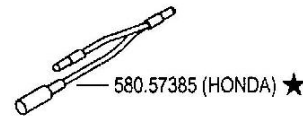

FERRARI

500 serie **95**

BODY
CARROCERIA

CARROZZERIA

CARROSSERIE
KAROSSERIE

DALLA MACCHINA
DE LA MAQUINA
DE LA MACHINE
FROM THE MACHINE
AB DER MASCHINE

★N.

AGGIORNAMENTO
REVISION
MISE A JOUR
APLAZAMIENTO
ANPASSUNG

01

Rev.
4

10/2001

ZENIT

Pos.	Code	Q.ty	Description	Notes
31111151	31111151	0	SCREW TE M8X16 UNI 5739 8G	
31112150	31112150	0	SCREW TE M8X20 UNI 5739 8G	
31112154	31112154	0	SCREW TE M8X40 UNI 5739 8G	
31112213	31112213	0	SCREW TE M10X40 UNI 5739	
31121007	31121007	0	SCREW BCEI M8X20 ISO7380	
31241080	31241080	0	HEXAGON SELFLOCK NUT M8	
31241100	31241100	0	SELFLOCK HEXAGON NUT M10	
31411084	31411084	0	WASHER 8,4x17	
31411104	31411104	0	WASHER 10,5x18	
31421083	31421083	0	WASHER	
31423084	31423084	0	SPRING WASHER 8,4	
55252316	55252316	0	BODYWORK	
56152241	56152241	0	CARROZZERIA MF LAT./97 *V*	
56156119	56156119	0	SHIELD	
58056991	58056991	0	CABLE GLAND	
58057385	58057385	0	LINE	
59047450	59047450	0	SHIELD	
59047927	59047927	0	SHIELD	
59056051	59056051	0	SHIELD	
59056089	59056089	0	SHIELD	
59056111	59056111	0	SHIELD	
59056982	59056982	0	HOLDER	
59056986	59056986	0	HOLDER	

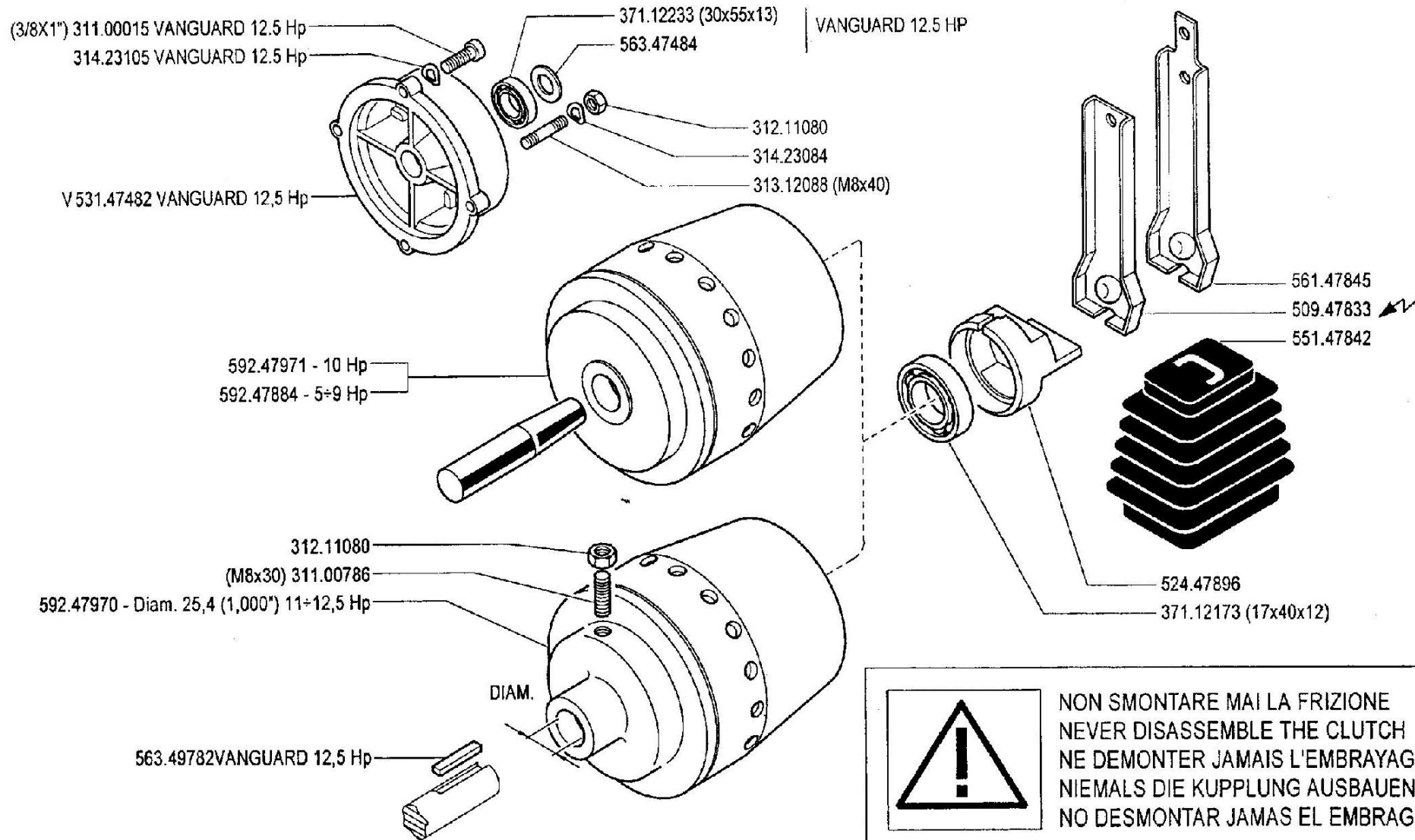

 NON SMONTARE MAI LA FRIZIONE
 NEVER DISASSEMBLE THE CLUTCH
 NE DEMONTER JAMAIS L'EMBRAYAGE
 NIEMALS DIE KUPPLUNG AUSBAUEN
 NO DESMONTAR JAMAS EL EMBRAGUE

V = verde - vert - green - grün

FERRARI

500 serie **95**

FRIZIONE A CONO AUTOVENTILANTE

EMBRAGUE
EMBRAYAGE

CLUTCH
KUPPLUNG

DALLA MACCHINA
DE LA MAQUINA
DE LA MACHINE
FROM THE MACHINE
AB DER MASCHINE

N.

02.00

01.06.1995

Pos.	Code	Q.ty	Description	Notes
31100015	31100015	0	SCREW TE 3/8X1	
31100786	31100786	0	SCREW STEI M8X30 UNI5923 8G	
31211080	31211080	0	NUT M8	
31312088	31312088	0	STUD BOLT M8X40X14X14	
31423084	31423084	0	SPRING WASHER 8,4	
31423105	31423105	0	SPRING WASHER 10,5	
37112173	37112173	0	BEARING	
37112233	37112233	0	BEARING	
50947833	50947833	0	CLUTCH LEVER	
52447896	52447896	0	PRESSURE PLATE	
53147482	53147482	0	ENGINE FLANGE	
55147842	55147842	0	BELLOWS	
56147845	56147845	0	CLUTCH LEVER	
56347484	56347484	0	SHIM	
56349782	56349782	0	DOWEL	
59247884	59247884	0	CLUTCH ASSY	
59247970	59247970	0	CLUTCH	
59247971	59247971	0	CLUTCH	

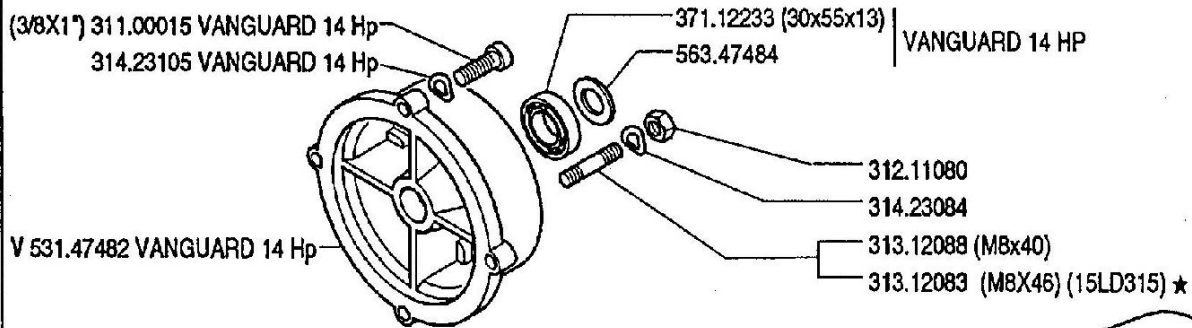

MOTORE ENGINE MOTEUR MOTOR	A	FRIZIONE EMBRAGUE EMBRAYAGE KUPPLUNG CLUTCH
Acme A220		592.47884
Acme ALN 330W		592.47884
Acme AT 330W		592.47971
Intermotor IM 359		592.47884
Briggs & Stratton Vanguard 14 Hp		592.47970
Lombardini 15 LD 315		592.47884
Lombardini 6 LD 435/400		592.47971

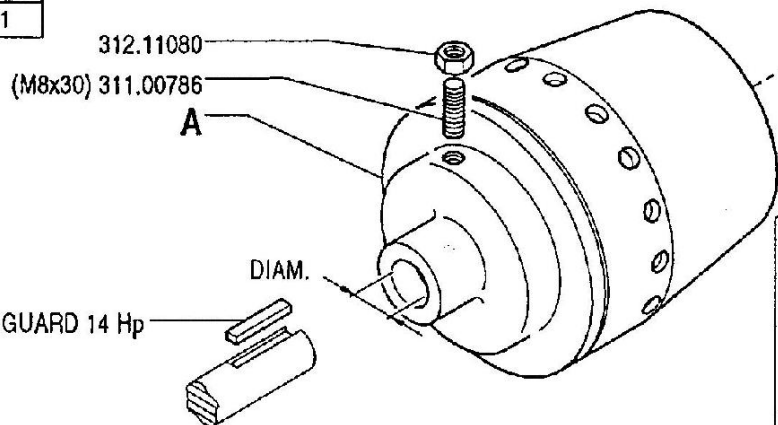
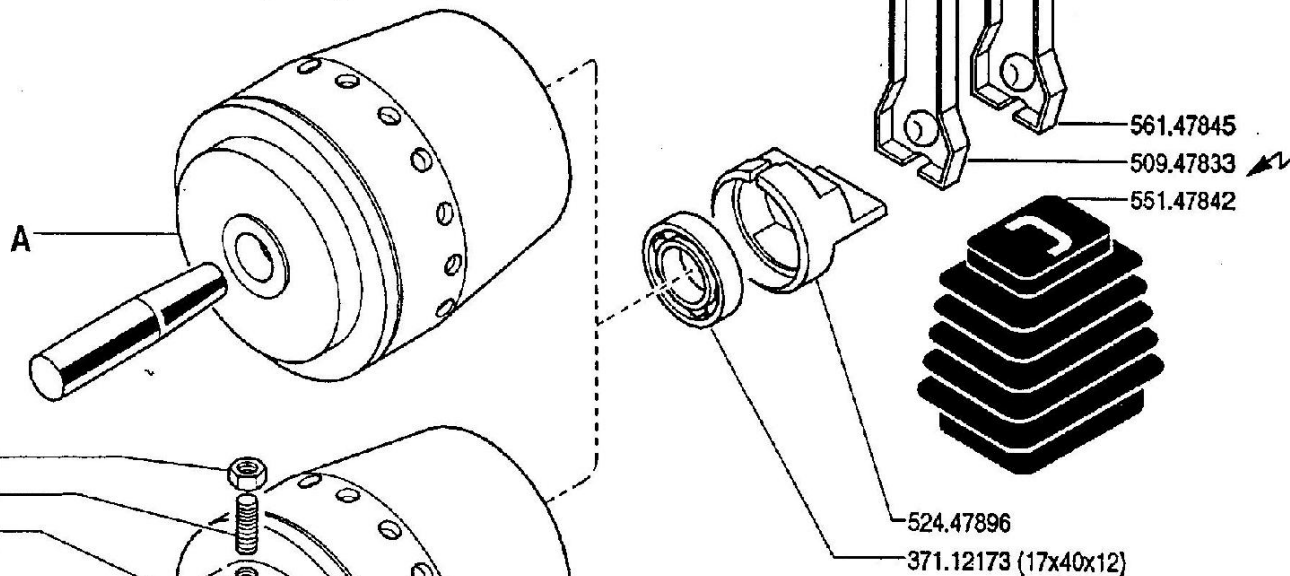

! NON SMONTARE MAI LA FRIZIONE
 NEVER DISASSEMBLE THE CLUTCH
 NE DEMONTER JAMAIS L'EMBRAYAGE
 NIEMALS DIE KUPPLUNG AUSBAUEN
 NO DESMONTAR JAMAS EL EMBRAGUE

V = verde - vert - green - grün

FERRARI	500 serie 95	FRIZIONE A CONO AUTOVENTILANTE		DALLA MACCHINA DE LA MAQUINA DE LA MACHINE FROM THE MACHINE AB DER MASCHINE	AGGIORNAMENTO	02.01
		EMBRAGUE	CLUTCH		REVISION	
		EMBRAYAGE	KUPPLUNG		MISE A JOUR	
					APLAZAMIENTO	
				★ N.	ANPASSUNG	02.09.1996

Pos.	Code	Q.ty	Description	Notes
31100015	31100015	0	SCREW TE 3/8X1	
31100786	31100786	0	SCREW STEI M8X30 UNI5923 8G	
31211080	31211080	0	NUT M8	
31312083	31312083	0	STUD BOLT M8X46X16X16	
31312088	31312088	0	STUD BOLT M8X40X14X14	
31423084	31423084	0	SPRING WASHER 8,4	
31423105	31423105	0	SPRING WASHER 10,5	
37112173	37112173	0	BEARING	
37112233	37112233	0	BEARING	
50947833	50947833	0	CLUTCH LEVER	
52447896	52447896	0	PRESSURE PLATE	
53147482	53147482	0	ENGINE FLANGE	
55147842	55147842	0	BELLOWS	
56147845	56147845	0	CLUTCH LEVER	
56347484	56347484	0	SHIM	
56349782	56349782	0	DOWEL	
59247884	59247884	0	CLUTCH ASSY	
59247970	59247970	0	CLUTCH	
59247971	59247971	0	CLUTCH	

★ (HONDA G150 - Gx160 - Gx200) 311.00003

371.12231 (HONDA G150 - Gx160 - Gx200) ★

563.56251 (HONDA G150 - Gx160 - Gx200) ★

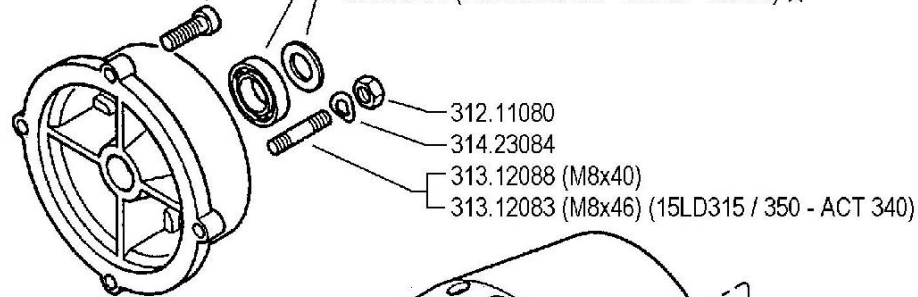

★ (HONDA G150 - Gx160 - Gx200) V 532.47468

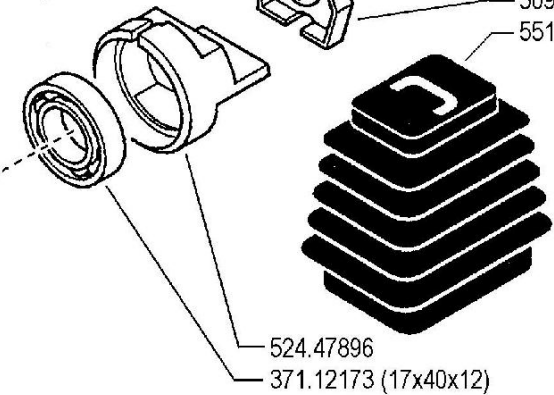
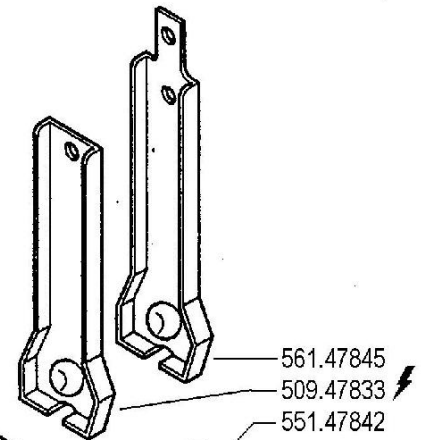
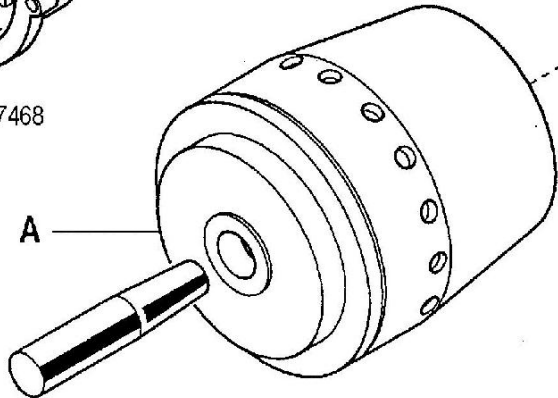

312.11080
(M8x30) 311.00786

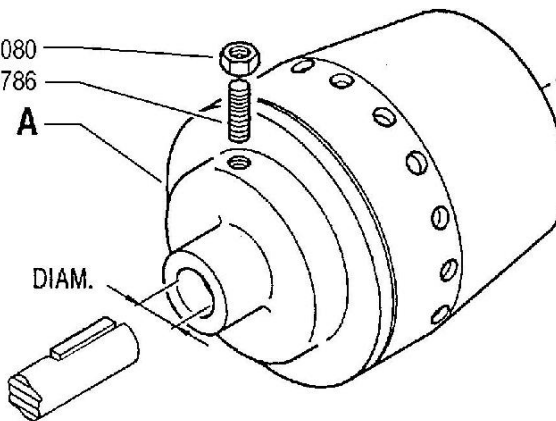

MOTORE ENGINE MOTEUR MOTOR	A	FRIZIONE EMBRAYAGE KUPPLUNG CLUTCH
Acme A 220		592.47884
Acme ALN 330W - ACT 280 ★		592.47884
Acme AT 330W - ACT 340 ★		592.47971
Honda G150 - Gx160 - Gx200 ★		592.56252
Intermotor IM 359		592.47884
Lombardini 15 LD 315 / 350		592.47884
Yanmar L100 AE ★		592.47971



**NON SMONTARE MAI LA FRIZIONE
NEVER DISASSEMBLE THE CLUTCH
NE DEMONTER JAMAIS L'EMBRAYAGE
NIEMALS DIE KUPPLUNG AUSBAUEN
NO DESMONTAR JAMAS EL EMBRAGUE**

V = verde - green - vert - grün

FERRARI	500 serie 95	FRIZIONE A CONO AUTOVENTILANTE		DALLA MACCHINA DE LA MAQUINA DE LA MACHINE FROM THE MACHINE AB DER MASCHINE	AGGIORNAMENTO	02	02
		CLUTCH	EMBRAYAGE		REVISION		
		EMBRAGUE	KUPPLUNG		MISE A JOUR		
					APLAZAMIENTO		
					ANPASSUNG		
			★N.	1/2000			

Pos.	Code	Q.ty	Description	Notes
31100003	31100003	0	SCREW TE 5/16X7/8	
31100786	31100786	0	SCREW STEI M8X30 UNI5923 8G	
31211080	31211080	0	NUT M8	
31312083	31312083	0	STUD BOLT M8X46X16X16	
31312088	31312088	0	STUD BOLT M8X40X14X14	
31423084	31423084	0	SPRING WASHER 8,4	
37112173	37112173	0	BEARING	
37112231	37112231	0	BEARING	
50947833	50947833	0	CLUTCH LEVER	
52447896	52447896	0	PRESSURE PLATE	
53247468	53247468	0	FLANGE	
55147842	55147842	0	BELLOWS	
56147845	56147845	0	CLUTCH LEVER	
56356251	56356251	0	SHIM D=19,6	
59247884	59247884	0	CLUTCH ASSY	
59247971	59247971	0	CLUTCH	
59256252	59256252	0	CLUTCH ASSY	

HONDA G150 - Gx 120/160/200 311.00003
 HONDA Gx 340 ★ 311.00015

HONDA Gx 340 ★ 314.23105

371.12231 HONDA G150 - Gx 120/160/200
 371.12233 (30x55x13) - HONDA Gx 340 ★

563.47484 - HONDA Gx 340 ★
 563.56251 HONDA G150 - Gx 120/160/200

312.11080
 314.23084

313.12088 (M8x40)
 313.12083 (M8x46) (15LD315/350 - ACT 280/340 - L100AE)

HONDA G150 - Gx 120/160/200 (2) ★ 532.47488
 HONDA Gx 340 ★ 531.56150

MOTORE ENGINE MOTEUR MOTOR	FRIZIONE EMBRAGUE EMBAYAGE KUPPLUNG CLUTCH
Acme A220	592.47884
Acme ACT 280 - A349 ★ - A360 ★	592.47884
Acme ACT 340	592.47971
Honda Gx 340 ★	592.56257
Honda G150 - Gx 120 / 160 / 200	592.56265 ★ (1)
Intermotor IM 359	592.47884
Lombardini 15LD315 / 350	592.47884
Yanmar L100AE	592.47971

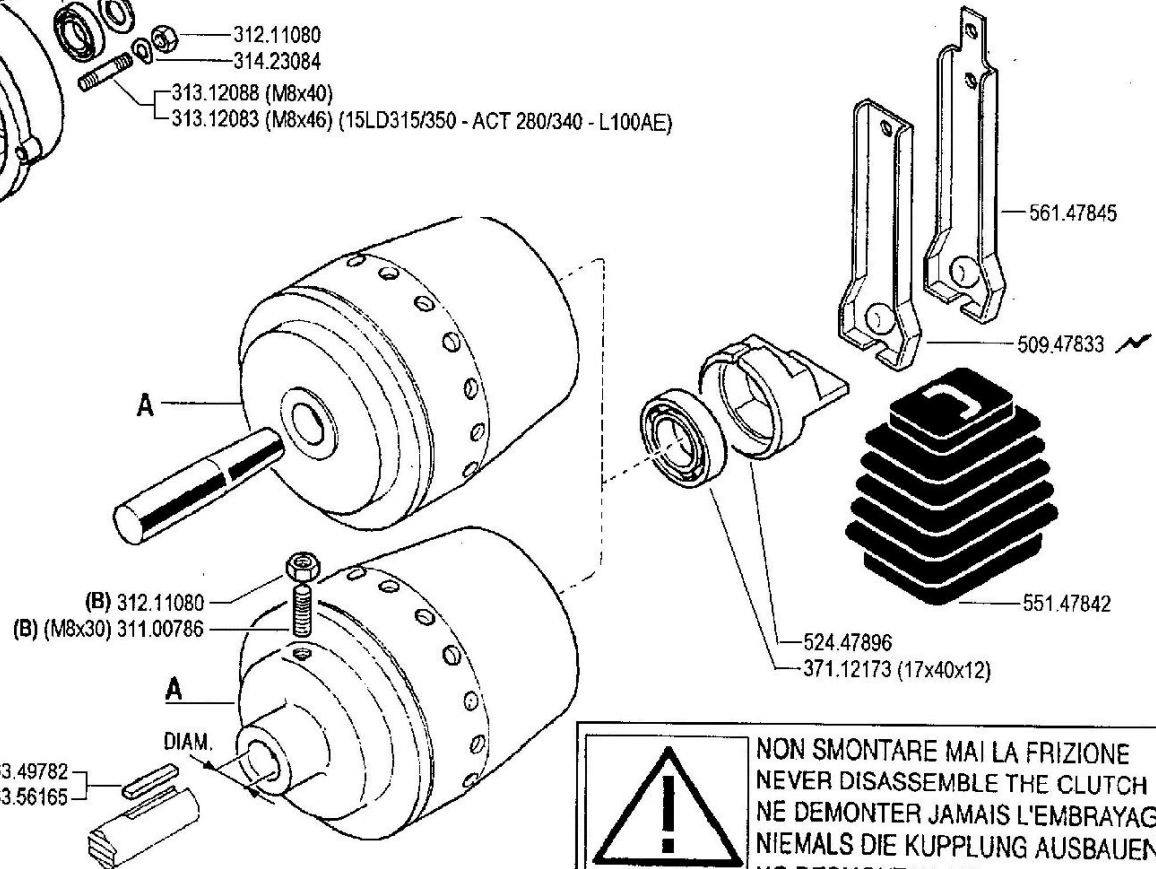

(HONDA Gx 340 ★) 563.49782
 (HONDA G150 - Gx120/160/200) ★ 563.56165

(2) sostituisce **V532.47468**
 (1) sostituisce **592.56252**

**! NON SMONTARE MAI LA FRIZIONE
 NEVER DISASSEMBLE THE CLUTCH
 NE DEMONTER JAMAIS L'EMBRAYAGE
 NIEMALS DIE KUPPLUNG AUSBAUEN
 NO DESMONTAR JAMAS EL EMBRAGUE**

(B) serrare a 2 kgm

FERRARI

500 serie 95

FRIZIONE A CONO AUTOVENTILANTE

CLUTCH
 EMBRAGUE

EMBRAYAGE
 KUPPLUNG

DALLA MACCHINA
 DE LA MAQUINA
 DE LA MACHINE
 FROM THE MACHINE
 AB DER MASCHINE

(1) 4194 (515)
 (1) 166207 (520)

02

Rev. **3**

★N.

12/2002

ZENNE

Pos.	Code	Q.ty	Description	Notes
31100003	31100003	0	SCREW TE 5/16X7/8	
31100015	31100015	0	SCREW TE 3/8X1	
31100786	31100786	0	SCREW STEI M8X30 UNI5923 8G	
31211080	31211080	0	NUT M8	
31312083	31312083	0	STUD BOLT M8X46X16X16	
31312088	31312088	0	STUD BOLT M8X40X14X14	
31423084	31423084	0	SPRING WASHER 8,4	
31423105	31423105	0	SPRING WASHER 10,5	
37112173	37112173	0	BEARING	
37112231	37112231	0	BEARING	
37112233	37112233	0	BEARING	
50947833	50947833	0	CLUTCH LEVER	
52447896	52447896	0	PRESSURE PLATE	
53156150	53156150	0	ENGINE FLANGE	
53247488	53247488	0	ENGINE FLANGE	
55147842	55147842	0	BELLOWS	
56147845	56147845	0	CLUTCH LEVER	
56347484	56347484	0	SHIM	
56349782	56349782	0	DOWEL	
56356165	56356165	0	DOWEL	
56356251	56356251	0	SHIM D=19,6	
59247884	59247884	0	CLUTCH ASSY	
59247971	59247971	0	CLUTCH	
59256257	59256257	0	CLUTCH ASSY	
59256265	59256265	0	CLUTCH ASSY	

SERIAL

002_03 - SELF-VENTILATING CONE CLUTCH

CODE REV

002_3_12779

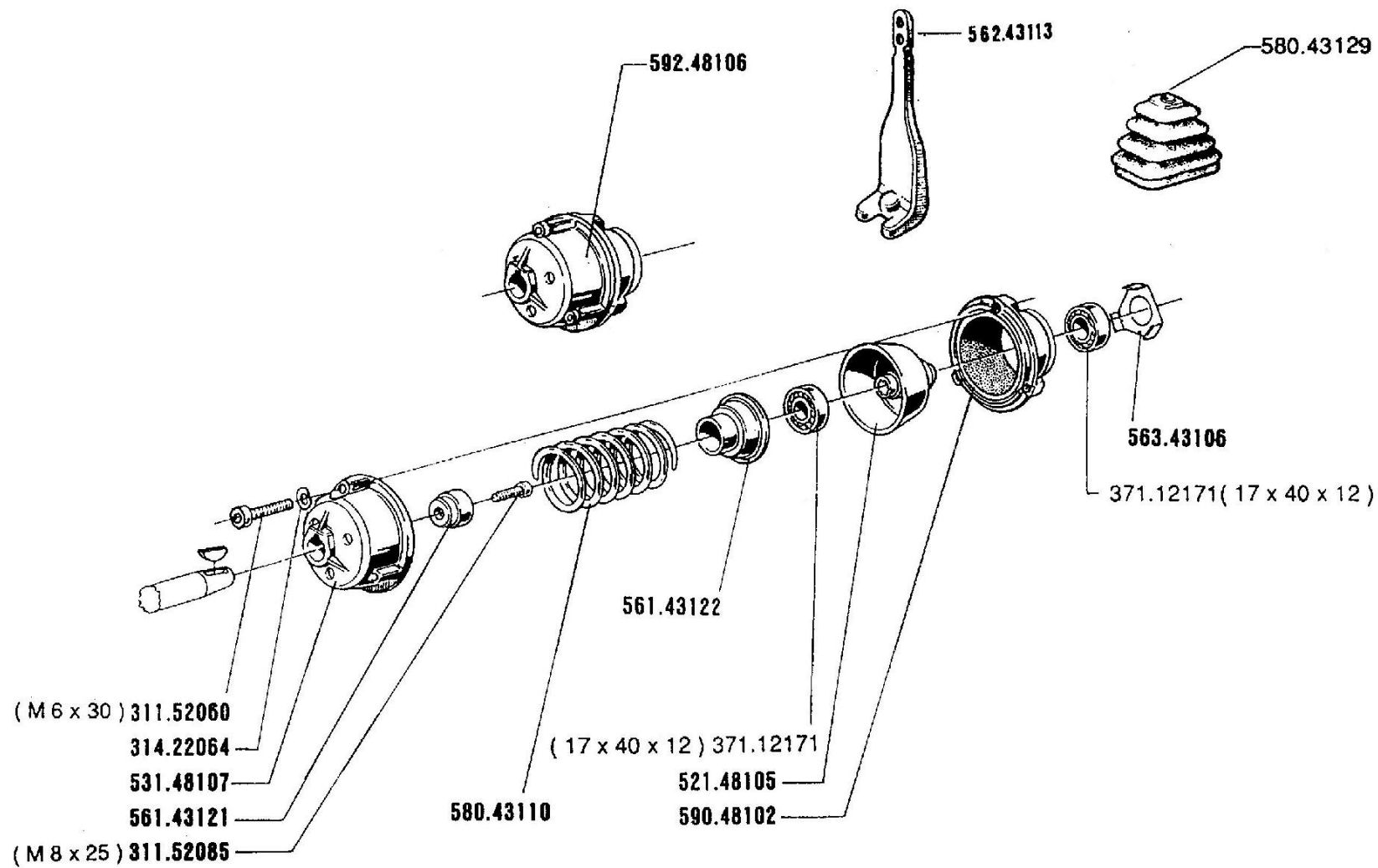

FERRARI

500 serie **95**

FRIZIONE (510)

CLUTCH
EMBRAGUE

EMBRAYAGE
KUPPLUNG

DALLA MACCHINA
DE LA MAQUINA
DE LA MACHINE
FROM THE MACHINE
AB DER MASCHINE

N.

02 A 00

10/1997

Mod

ZENIT

Pos.	Code	Q.ty	Description	Notes
31152060	31152060	0	SCREW TCEI M6X30 UNI 5931	
31152085	31152085	0	SCREW TCEI M8X25 UNI 5931	
31422064	31422064	0	SPRING WASHER 6,4	
37112171	37112171	0	BEARING	
52148105	52148105	0	FRICTION CONE	
53148107	53148107	0	CLUTCH HOUSING	
56143121	56143121	0	PAD	
56143122	56143122	0	BUSHING	
56243113	56243113	0	CLUTCH LEVER	
56343106	56343106	0	SMALL PLATE	
58043110	58043110	0	COUPLING SPRING	
58043129	58043129	0	BELLOWS	
59048102	59048102	0	CLUTCH THRUST RING	
59248106	59248106	0	CLUTCH	

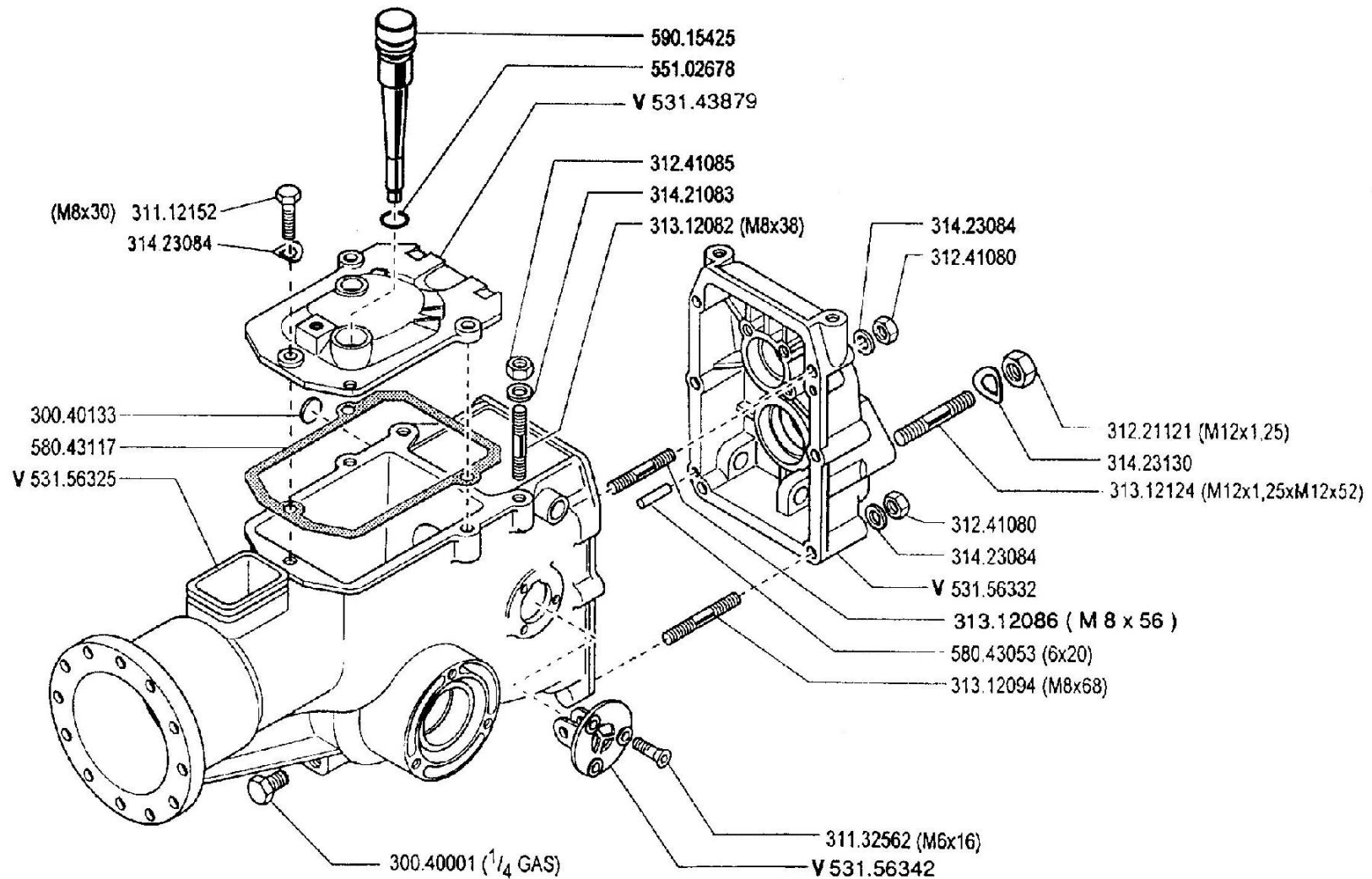

V = verde - vert - green - grün

	500 serie 95	SCATOLA CAMBIO (510)		DALLA MACCHINA DE LA MAQUINA DE LA MACHINE FROM THE MACHINE AB DER MASCHINE	N.	03	A00
		CAJA DE CAMBIO BOITE DE VITESSES	GEARBOX WECHSELGETRIEBE			10/1997	

Pos.	Code	Q.ty	Description	Notes
30040001	30040001	0	PLUG	
30040133	30040133	0	PLUG 22 DIN 470	
31112152	31112152	0	SCREW TE M8X30 UNI 5739 8G	
31132562	31132562	0	SCREW TSVEI M6X16 UNI 5933	
31221121	31221121	0	NUT M12X1,25	
31241080	31241080	0	HEXAGON SELFLOCK NUT M8	
31241085	31241085	0	SELFLOCK NUT M8 6S	
31312082	31312082	0	STUD BOLT M8X38X14X20	
31312086	31312086	0	STUD BOLT M8X56X20X14	
31312094	31312094	0	STUD BOLT M8X68X14X36	
31312124	31312124	0	STUD BOLT	
31421083	31421083	0	WASHER	
31423084	31423084	0	SPRING WASHER 8,4	
31423130	31423130	0	SPRING WASHER 13	
53143879	53143879	0	GEARBOX HOUSING COVER	
53156325	53156325	0	BODY	
53156332	53156332	0	REAR COVER	
53156342	53156342	0	GEAR SUPPORT	
55102678	55102678	0	RUBBER RING	
58043053	58043053	0	CYLINDRICAL PLUG	
58043117	58043117	0	COVER GASKET	
59015425	59015425	0	PLUG	

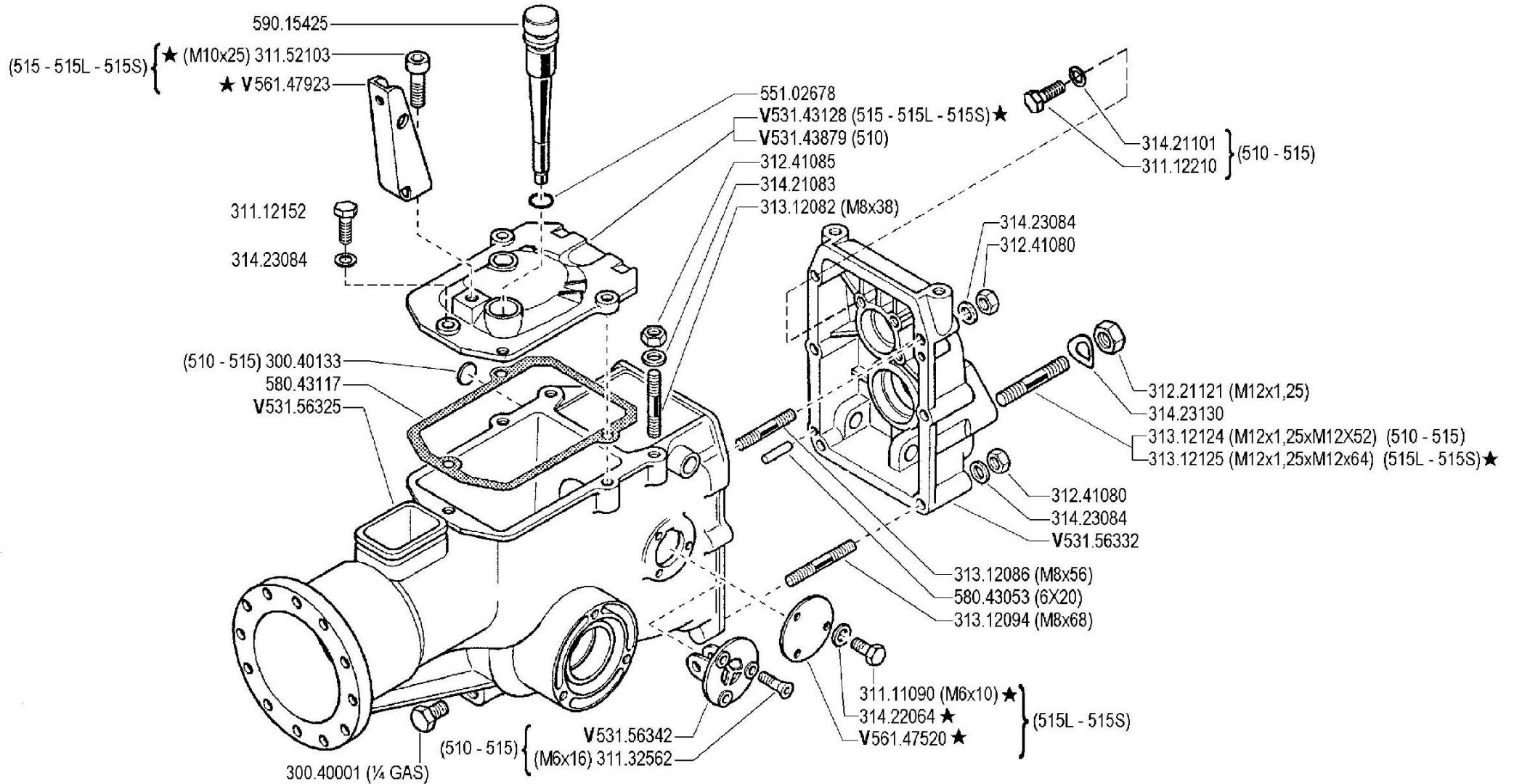

V = verde - green - vert - grün

	500 serie 95	SCATOLA CAMBIO (510 - 515 - 515L - 515S)		DALLA MACCHINA DE LA MAQUINA DE LA MACHINE FROM THE MACHINE AB DER MASCHINE	AGGIORNAMENTO	03 A 01	/Mod. 1/2000
		GEARBOX	BOITE DE VITESSES		REVISION		
		CAJA DE CAMBIO	WECHSELGETRIEBE		MISE A JOUR		
					APLAZAMIENTO		
					ANPASSUNG		
				★N.			

Pos.	Code	Q.ty	Description	Notes
30040001	30040001	0	PLUG	
30040133	30040133	0	PLUG 22 DIN 470	
31111090	31111090	0	SCREW TE M5X10 UNI 5739 8G	
31112152	31112152	0	SCREW TE M8X30 UNI 5739 8G	
31112210	31112210	0	SCREW TE M10X20 UNI 5739	
31132562	31132562	0	SCREW TSVEI M6X16 UNI 5933	
31152103	31152103	0	SCREW TCEI M10X25 UNI 5931	
31221121	31221121	0	NUT M12X1,25	
31241080	31241080	0	HEXAGON SELFLOCK NUT M8	
31241085	31241085	0	SELFLOCK NUT M8 6S	
31312082	31312082	0	STUD BOLT M8X38X14X20	
31312086	31312086	0	STUD BOLT M8X56X20X14	
31312094	31312094	0	STUD BOLT M8X68X14X36	
31312124	31312124	0	STUD BOLT	
31312125	31312125	0	STUD BOLT	
31421083	31421083	0	WASHER	
31421101	31421101	0	WASHER	
31422064	31422064	0	SPRING WASHER 6,4	
31423084	31423084	0	SPRING WASHER 8,4	
31423130	31423130	0	SPRING WASHER 13	
53143128	53143128	0	COVER	
53143879	53143879	0	GEARBOX HOUSING COVER	
53156325	53156325	0	BODY	
53156332	53156332	0	REAR COVER	
53156342	53156342	0	GEAR SUPPORT	
55102678	55102678	0	RUBBER RING	
56147520	56147520	0	COVER	
56147923	56147923	0	BRACKET	
58043053	58043053	0	CYLINDRICAL PLUG	
58043117	58043117	0	COVER GASKET	
59015425	59015425	0	PLUG	

SERIAL

GEARBOX (510-515-515L-515S)

CODE REV

03A_1_13913

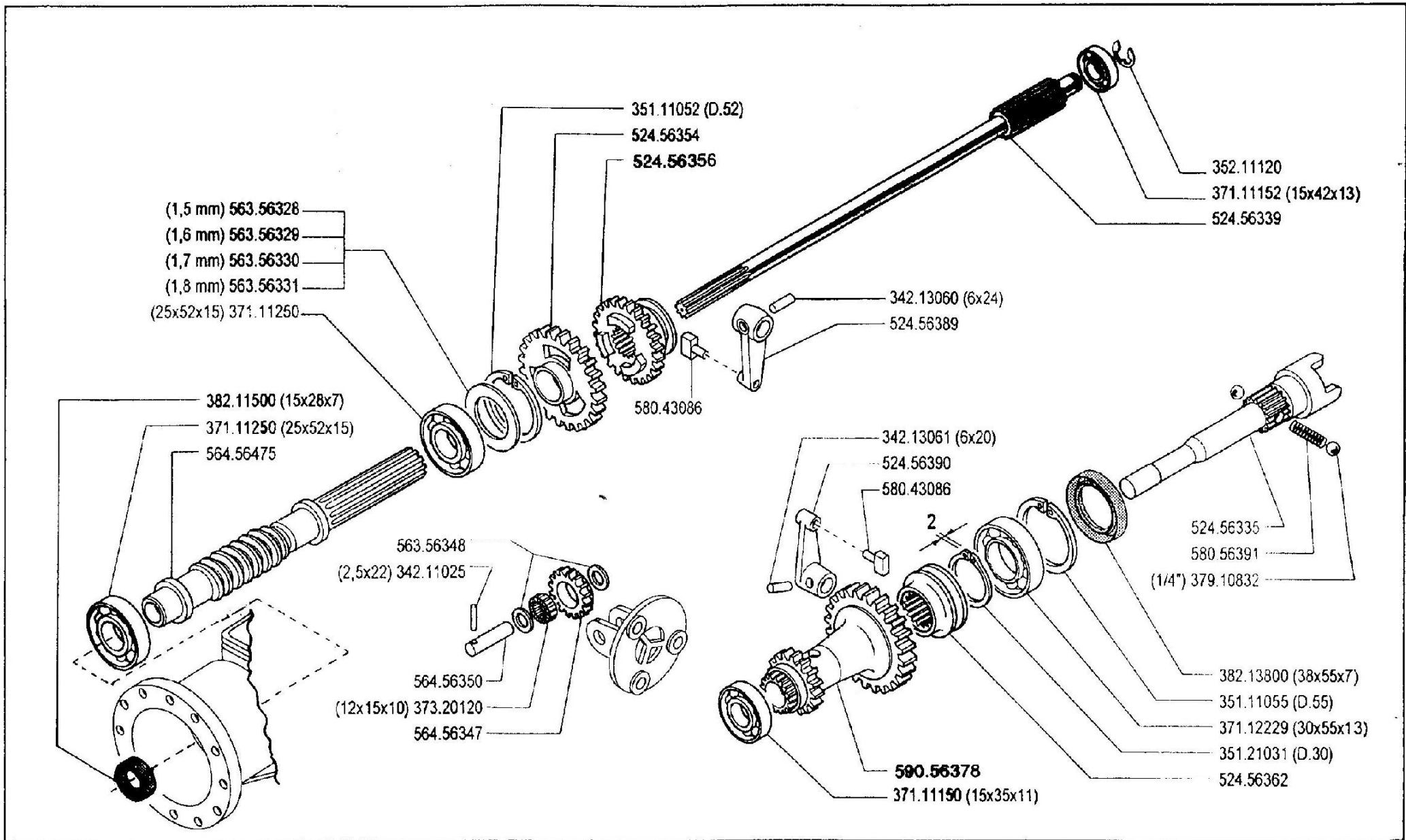

FERRARI

500 serie **95**

INGRANAGGI CAMBIO (510)

ENGRANAJES
ENGRANAGES

GEARS
ZAHNRÄDER

DALLA MACCHINA
DE LA MAQUINA
DE LA MACHINE
FROM THE MACHINE
AB DER MASCHINE

N.

04 A00

10/1997

Pos.	Code	Q.ty	Description	Notes
34211025	34211025	0	ROLL PIN	
34213060	34213060	0	ROLL PIN	
34213061	34213061	0	ROLL PIN	
35111052	35111052	0	SEEGER RING	
35111055	35111055	0	SEEGER RING	
35121031	35121031	0	SEEGER RING	
35211120	35211120	0	SEEGER RING	
37111150	37111150	0	BEARING	
37111152	37111152	0	BEARING	
37111250	37111250	0	BEARING	
37112229	37112229	0	BEARING	
37320120	37320120	0	ROLLER CAGE 12X15/10	
37910832	37910832	0	BALL 1/4	
38211500	38211500	0	OIL SEAL 15X28X7	
38213800	38213800	0	OIL SEAL 38X55X7	
52456335	52456335	0	PTO SHAFT	
52456339	52456339	0	SHAFT	
52456354	52456354	0	GEAR	
52456356	52456356	0	SLIDER	
52456362	52456362	0	COUPLING	
52456389	52456389	0	LEVER	
52456390	52456390	0	LEVER	
56356328	56356328	0	ADJUSTING RING SP=1,5	
56356329	56356329	0	ADJUSTING RING SP=1,6	
56356330	56356330	0	ADJUSTING RING SP=1,7	
56356331	56356331	0	ADJUSTING RING SP=1,8	
56356348	56356348	0	ADJUSTING RING	
56456347	56456347	0	GEAR	
56456350	56456350	0	GEAR PIN	
56456475	56456475	0	SCREW	
58043086	58043086	0	SHOE	
58056391	58056391	0	SPRING	
59056378	59056378	0	TRANSMISSION SHAFT	

SERIAL

GEARS (510)

CODE REV

04A_0_14000

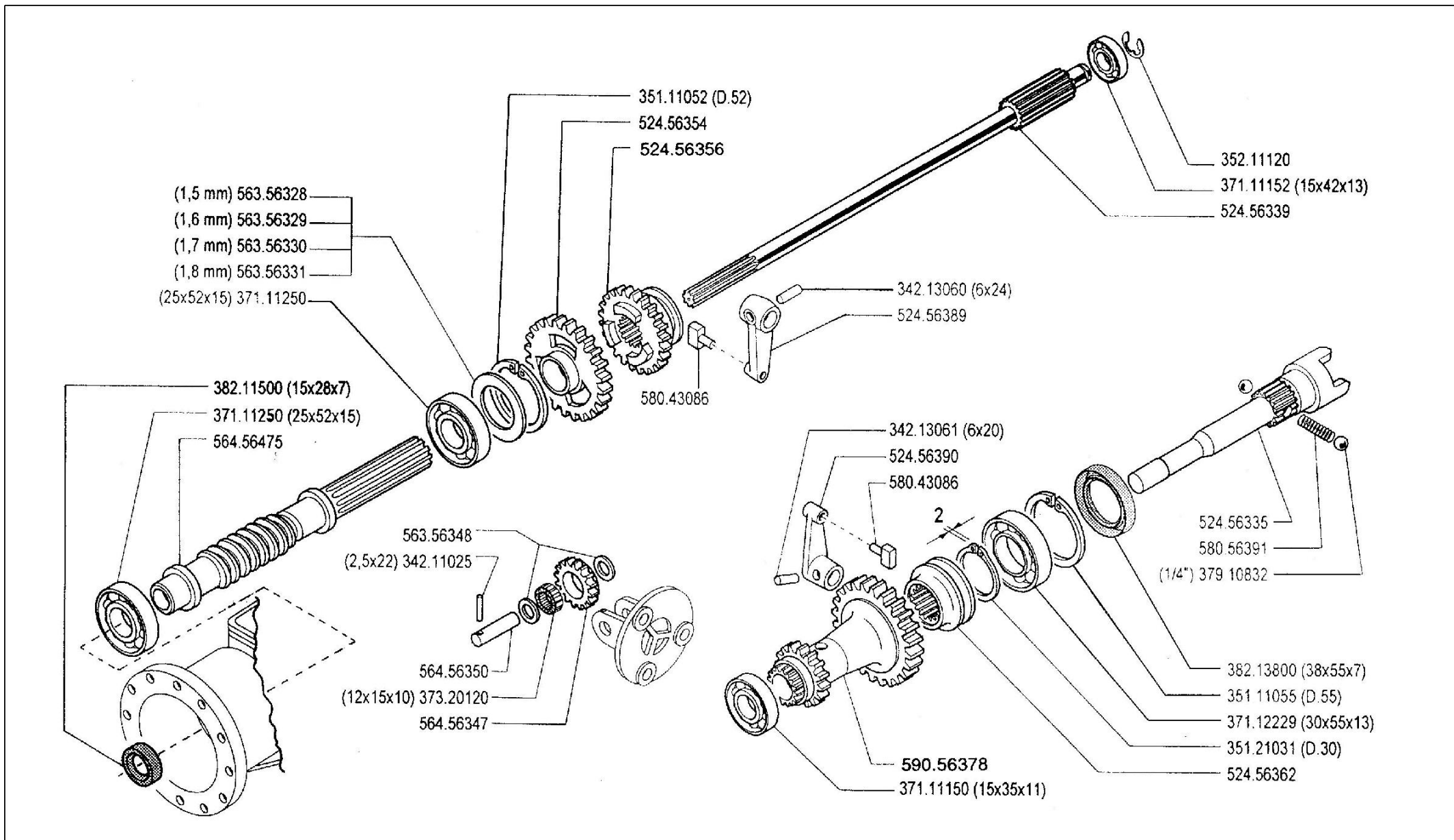

FERRARI

500 serie **95**

INGRANAGGI CAMBIO (510 - 515★)

GEARS
ENGRANAJES

ENGRANAGES
ZÄHRÄDER

DALLA MACCHINA
DE LA MAQUINA
DE LA MACHINE
FROM THE MACHINE
AB DER MASCHINE

★N.

AGGIORNAMENTO
REVISION
MISE A JOUR
APLAZAMIENTO
ANPASSUNG

04 A	01	I/od.
		1/2000

Pos.	Code	Q.ty	Description	Notes
34211025	34211025	0	ROLL PIN	
34213060	34213060	0	ROLL PIN	
34213061	34213061	0	ROLL PIN	
35111052	35111052	0	SEEGER RING	
35111055	35111055	0	SEEGER RING	
35121031	35121031	0	SEEGER RING	
35211120	35211120	0	SEEGER RING	
37111150	37111150	0	BEARING	
37111152	37111152	0	BEARING	
37111250	37111250	0	BEARING	
37112229	37112229	0	BEARING	
37320120	37320120	0	ROLLER CAGE 12X15/10	
37910832	37910832	0	BALL 1/4	
38211500	38211500	0	OIL SEAL 15X28X7	
38213800	38213800	0	OIL SEAL 38X55X7	
52456335	52456335	0	PTO SHAFT	
52456339	52456339	0	SHAFT	
52456354	52456354	0	GEAR	
52456356	52456356	0	SLIDER	
52456362	52456362	0	COUPLING	
52456389	52456389	0	LEVER	
52456390	52456390	0	LEVER	
56356328	56356328	0	ADJUSTING RING SP=1,5	
56356329	56356329	0	ADJUSTING RING SP=1,6	
56356330	56356330	0	ADJUSTING RING SP=1,7	
56356331	56356331	0	ADJUSTING RING SP=1,8	
56356348	56356348	0	ADJUSTING RING	
56456347	56456347	0	GEAR	
56456350	56456350	0	GEAR PIN	
56456475	56456475	0	SCREW	
58043086	58043086	0	SHOE	
58056391	58056391	0	SPRING	
59056378	59056378	0	TRANSMISSION SHAFT	

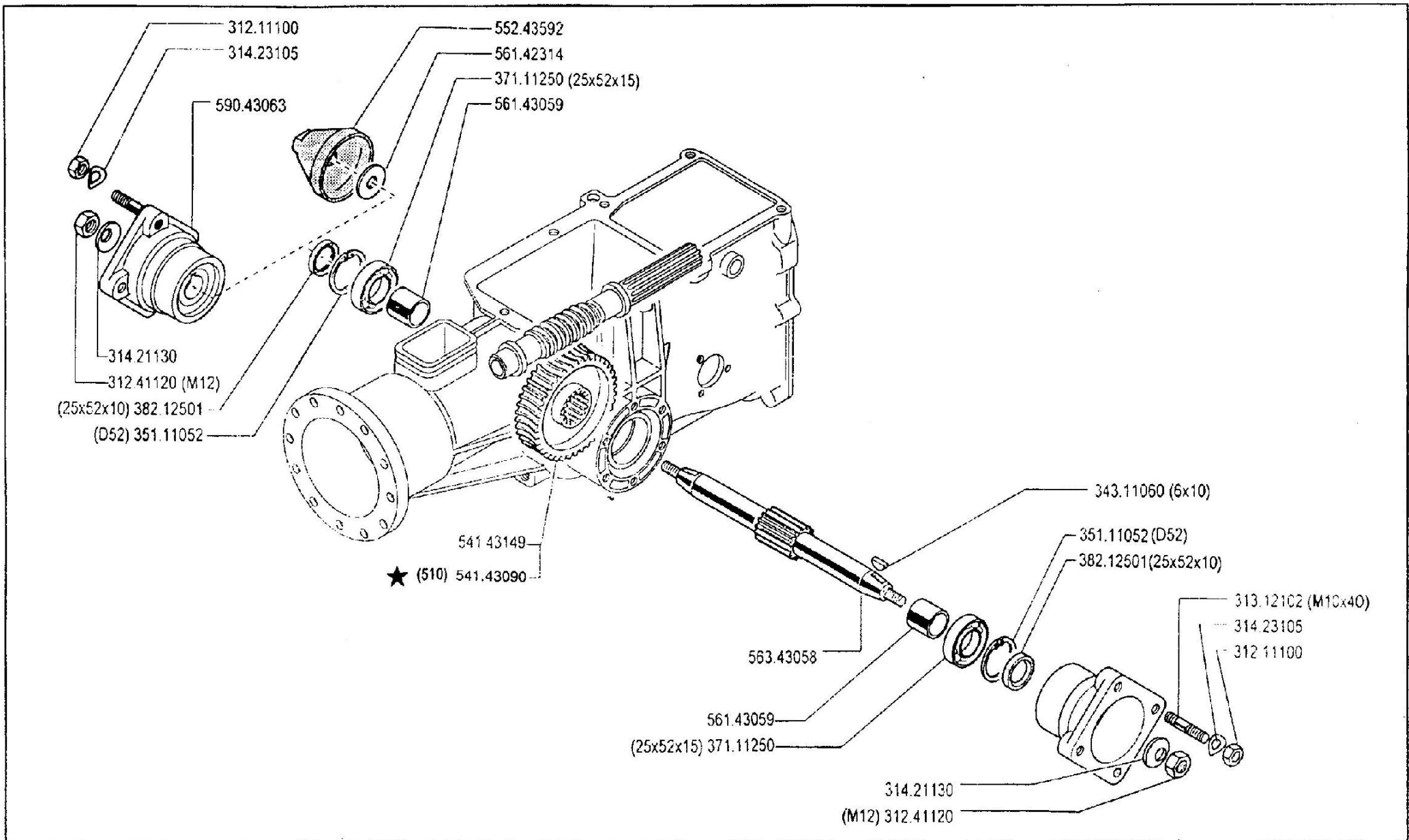

FERRARI	500 serie 95	ASSE RUOTE (500-510-520)		DALLA MACCHINA	AGGIORNAMENTO	05 .01
		EJE RUEDAS	WHEEL AXLE	DE LA MAQUINA	REVISION	
		ESSIEU ROUES	RADACHSE	DE LA MACHINE	MISE A JOUR	
				FROM THE MACHINE	APLAZAMIENTO	
				AB DER MASCHINE	ANPASSUNG	10/1997
				★ N.		

Pos.	Code	Q.ty	Description	Notes
31211100	31211100	0	NUT M10	
31241120	31241120	0	SELFLOCK NUT M12	
31312102	31312102	0	STUD BOLT M10X40X24X12	
31421130	31421130	0	WASHER	
31423105	31423105	0	SPRING WASHER 10,5	
34311060	34311060	0	KEY 6X10 UNI 6606	
35111052	35111052	0	SEEGER RING	
37111250	37111250	0	BEARING	
38212501	38212501	0	OIL SEAL 25X52X10	
54143090	54143090	0	CROWN WHEEL	
54143149	54143149	0	CROWN WHEEL	
55243592	55243592	0	CAP	
56142314	56142314	0	WASHER 12,5x34/4	
56143059	56143059	0	SPACER	
56343058	56343058	0	AXLE SHAFT	
59043063	59043063	0	WHEEL HUB	

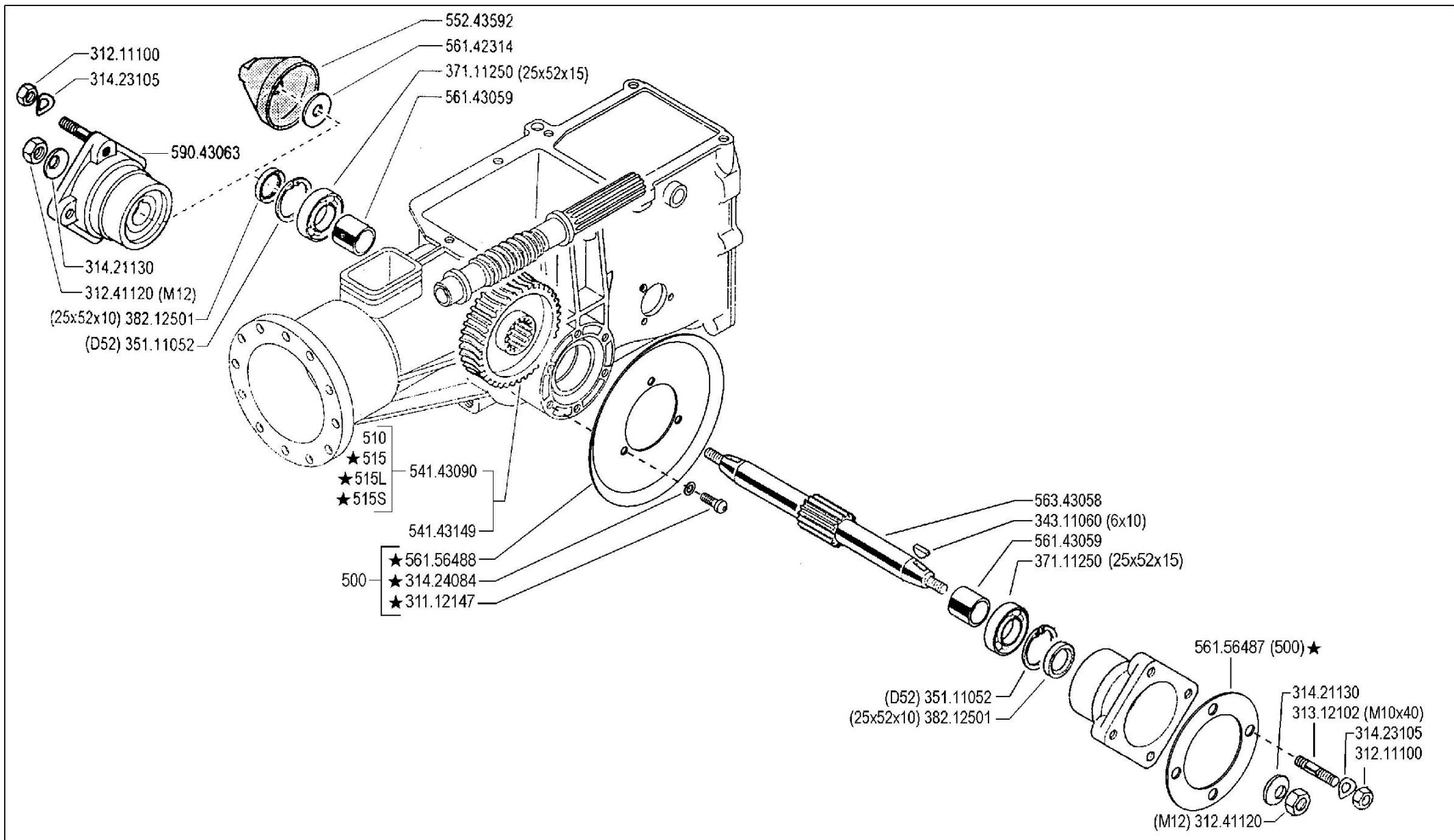

FERRARI	<h1>500</h1> serie 95	ASSE RUOTE (500 - 510 - 515 - 515L - 515S - 520)		DALLA MACCHINA DE LA MAQUINA DE LA MACHINE FROM THE MACHINE AB DER MASCHINE	AGGIORNAMENTO	05	Mod. 02
		WHEELS AXLE	ESSIEU ROUES		REVISION		
		EJE RUEDAS	RADACHSE		MISE A JOUR		
					APLAZAMIENTO		
					ANPASSUNG		
		★N.	1/2000				

Pos.	Code	Q.ty	Description	Notes
31112147	31112147	0	SCREW TE M8X18 UNI 5739 8G	
31211100	31211100	0	NUT M10	
31241120	31241120	0	SELFLOCK NUT M12	
31312102	31312102	0	STUD BOLT M10X40X24X12	
31421130	31421130	0	WASHER	
31423105	31423105	0	SPRING WASHER 10,5	
31424084	31424084	0	SPRING WASHER 8,4	
34311060	34311060	0	KEY 6X10 UNI 6606	
35111052	35111052	0	SEEGER RING	
37111250	37111250	0	BEARING	
38212501	38212501	0	OIL SEAL 25X52X10	
54143090	54143090	0	CROWN WHEEL	
54143149	54143149	0	CROWN WHEEL	
55243592	55243592	0	CAP	
56142314	56142314	0	WASHER 12,5x34/4	
56143059	56143059	0	SPACER	
56156487	56156487	0	SPACER	
56156488	56156488	0	GUARD	
56343058	56343058	0	AXLE SHAFT	
59043063	59043063	0	WHEEL HUB	

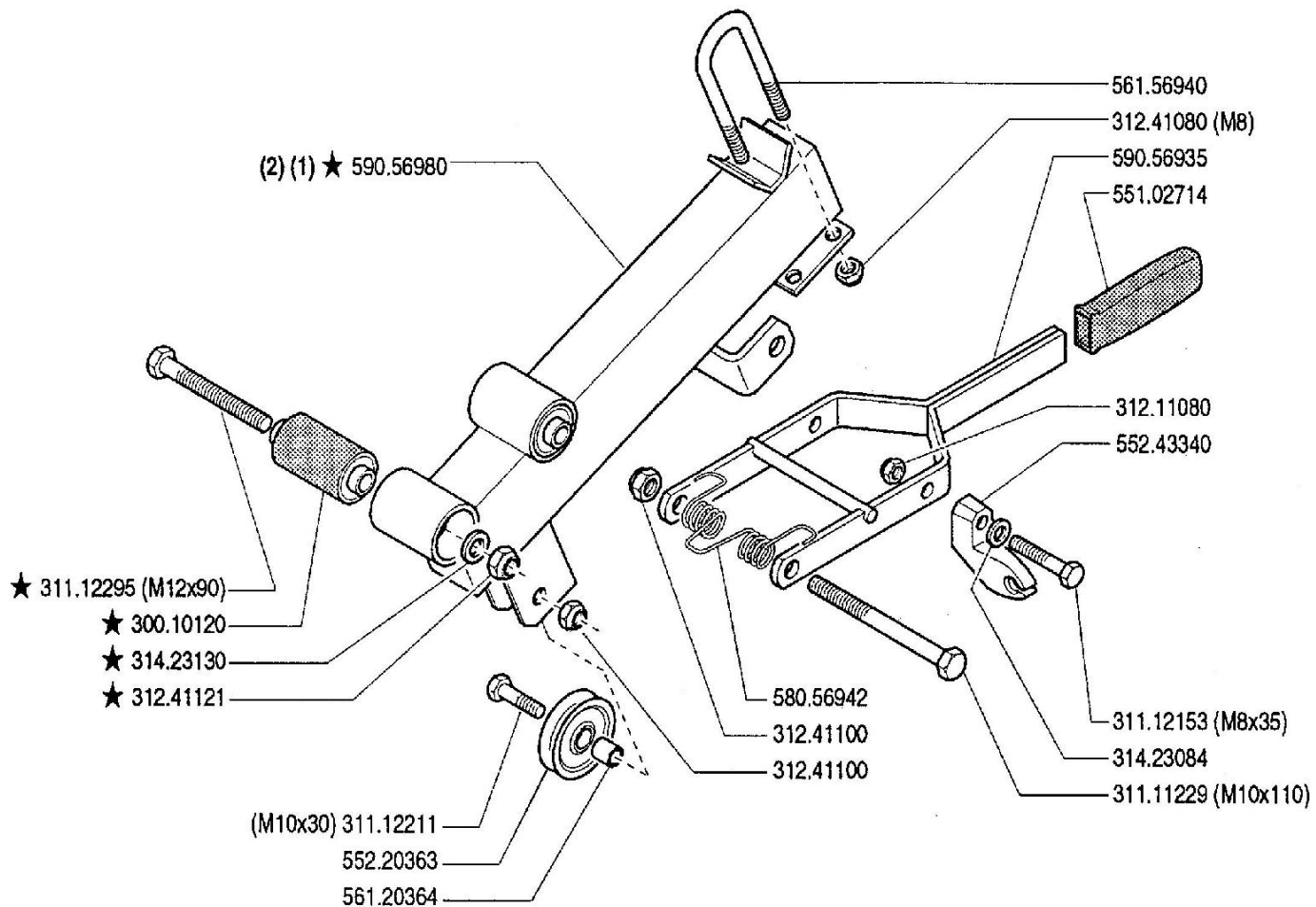

(1) (520 - 530) { tav. 07.02 }
 (2) (500) { tav. 01.02 } sostituisce 590.56925
 { tav. 09.02 }

FERRARI

500 serie **95**

PIANTONE (500-510-520-530)

STEERING COLUMN
COLUMNNA

PLANTON
LENKSÄULE

DALLA MACCHINA
DE LA MAQUINA
DE LA MACHINE
FROM THE MACHINE
AB DER MASCHINE

★N.

22690 (530)

158833 (520)

80952 (500)

07 **02**

9/1997

Mod

ZENIT

Pos.	Code	Q.ty	Description	Notes
30010120	30010120	0	SILENT-BLOCK 12X40X58X66	
31111229	31111229	0	SCREW TE M10X110 UNI 5737 8G	
31112153	31112153	0	SCREW TE M8X35 UNI 5739 8G	
31112211	31112211	0	SCREW TE M10X30 UNI 5739	
31112295	31112295	0	SCREW TE M12X90 UNI 5737	
31211080	31211080	0	NUT M8	
31241080	31241080	0	HEXAGON SELFLOCK NUT M8	
31241100	31241100	0	SELFLOCK HEXAGON NUT M10	
31241121	31241121	0	SELFLOCK NUT M12	
31423084	31423084	0	SPRING WASHER 8,4	
31423130	31423130	0	SPRING WASHER 13	
55102714	55102714	0	KNOB	
55220363	55220363	0	PULLEY	
55243340	55243340	0	SUPPORT	
56120364	56120364	0	SLEEVE	
56156940	56156940	0	U BOLT	
58056942	58056942	0	SPRING	
59056935	59056935	0	LEVER	
59056980	59056980	0	COLUMN	

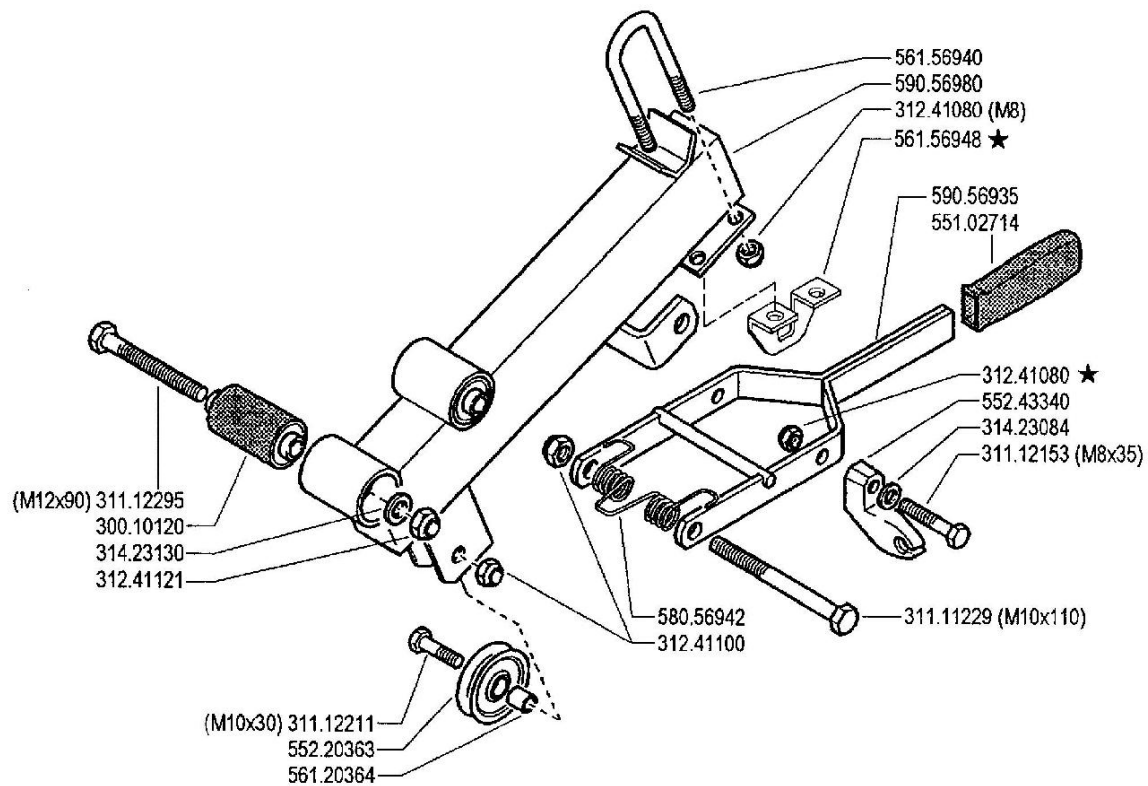

FERRARI

500 serie **95**

PIANTONE (500 - 510 - 520 - 530 - 530S - 530S2)

STEERING COLUMN
COLUMNNA

PLANTON
LENKSÄULE

DALLA MACCHINA
DE LA MAQUINA
DE LA MACHINE
FROM THE MACHINE
AB DER MASCHINE

★N

AGGIORNAMENTO
REVISION
MISE A JOUR
APLAZAMIENTO
ANPASSUNG

07

Rev.
3

12/2002

ZENNE

Pos.	Code	Q.ty	Description	Notes
30010120	30010120	0	SILENT-BLOCK 12X40X58X66	
31111229	31111229	0	SCREW TE M10X110 UNI 5737 8G	
31112153	31112153	0	SCREW TE M8X35 UNI 5739 8G	
31112211	31112211	0	SCREW TE M10X30 UNI 5739	
31112295	31112295	0	SCREW TE M12X90 UNI 5737	
31241080	31241080	0	HEXAGON SELFLOCK NUT M8	
31241100	31241100	0	SELFLOCK HEXAGON NUT M10	
31241121	31241121	0	SELFLOCK NUT M12	
31423084	31423084	0	SPRING WASHER 8,4	
31423130	31423130	0	SPRING WASHER 13	
55102714	55102714	0	KNOB	
55220363	55220363	0	PULLEY	
55243340	55243340	0	SUPPORT	
56120364	56120364	0	SLEEVE	
56156940	56156940	0	U BOLT	
56156948	56156948	0	STOP	
58056942	58056942	0	SPRING	
59056935	59056935	0	LEVER	
59056980	59056980	0	COLUMN	

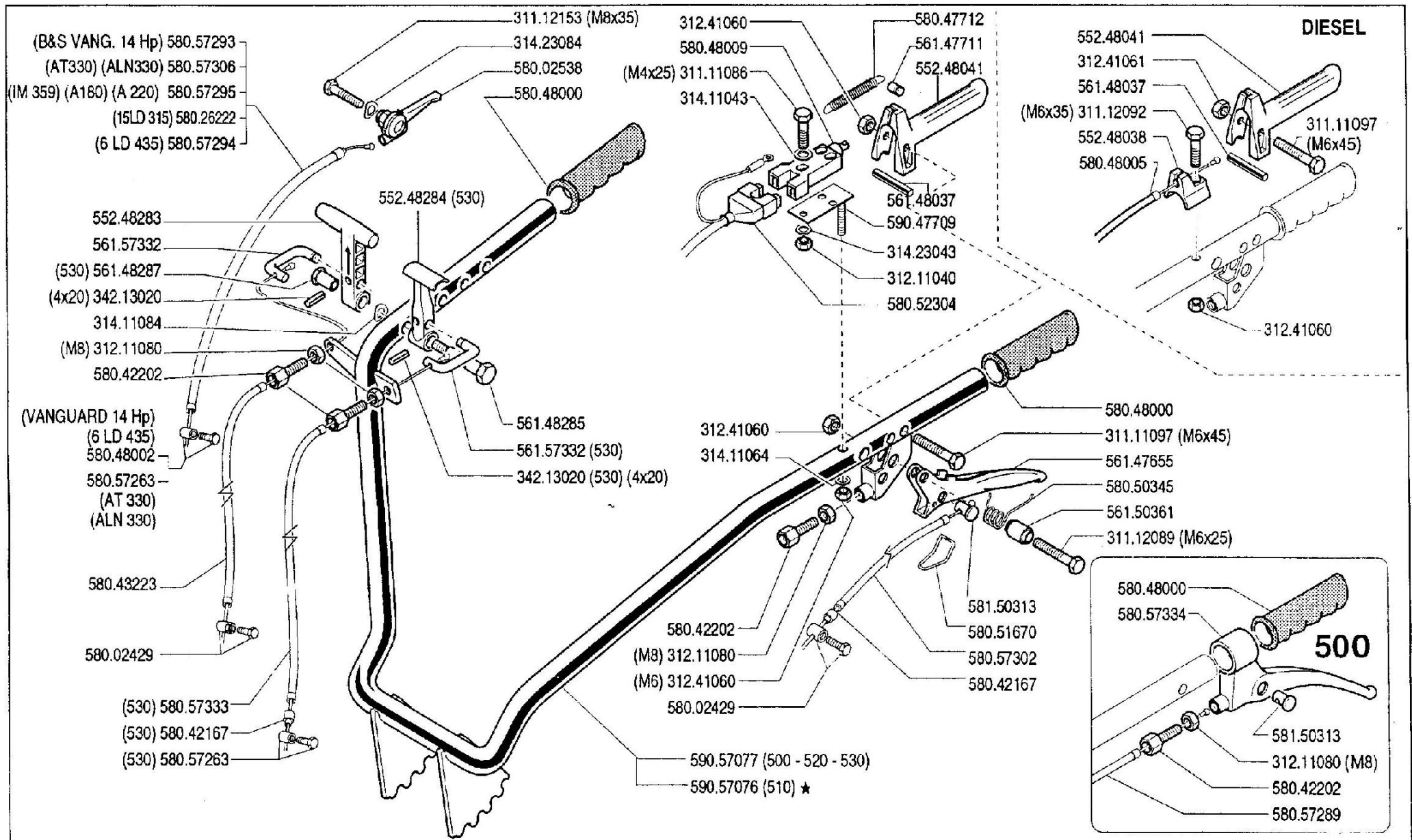

FERRARI

500 serie 95

MANUBRIO

MANILLAR
 MANCHERON

HANDLEBAR
 LENKER

DALLA MACCHINA
 DE LA MAQUINA
 DE LA MACHINE
 FROM THE MACHINE
 AB DER MASCHINE

AGGIORNAMENTO
 REVISION
 MISE A JOUR
 APLAZAMIENTO
 ANPASSUNG

08.02

9/1997

★ N.

Pos.	Code	Q.ty	Description	Notes
31111086	31111086	0	SCREW TE M4X25 UNI 5739 8G	
31111097	31111097	0	SCREW TE M6X45 UNI 5737 8G	
31112089	31112089	0	SCREW TE M6X25 UNI 5739 8G	
31112092	31112092	0	SCREW TE M6X35 UNI 5739 8G	
31112153	31112153	0	SCREW TE M8X35 UNI 5739 8G	
31211040	31211040	0	NUT M4	
31211080	31211080	0	NUT M8	
31241060	31241060	0	HEXAGON SELFLOCK NUT M6	
31241061	31241061	0	SELFLOCK NUT M6 6S	
31411043	31411043	0	WASHER 4,3X9	
31411064	31411064	0	WASHER 6,4x12,5	
31411084	31411084	0	WASHER 8,4x17	
31423043	31423043	0	SPRING WASHER 4,3	
31423084	31423084	0	SPRING WASHER 8,4	
34213020	34213020	0	ROLL PIN	
55248038	55248038	0	STOP	
55248041	55248041	0	LEVER	
55248283	55248283	0	COMMAND LEVER	
55248284	55248284	0	LEVER	
56147655	56147655	0	CLUTCH LEVER	
56147711	56147711	0	PIN	
56148037	56148037	0	LEVER STOP	
56148285	56148285	0	PIN	
56148287	56148287	0	STUD BOLT	
56150361	56150361	0	SPACER	
56157332	56157332	0	U BOLT	
58002429	58002429	0	CLAMPING SCREW	
58002538	58002538	0	COMMAND LEVER	
58026222	58026222	0	LINE AND SHEATH	
58042167	58042167	0	SHEATH TERMINAL	
58042202	58042202	0	ADJUSTING SCREW	
58043223	58043223	0	LINE AND SHEATH	
58047712	58047712	0	SPRING	
58048000	58048000	0	KNOB	

SERIAL

008_02 - HANDLEBAR

CODE REV

008_2_13308

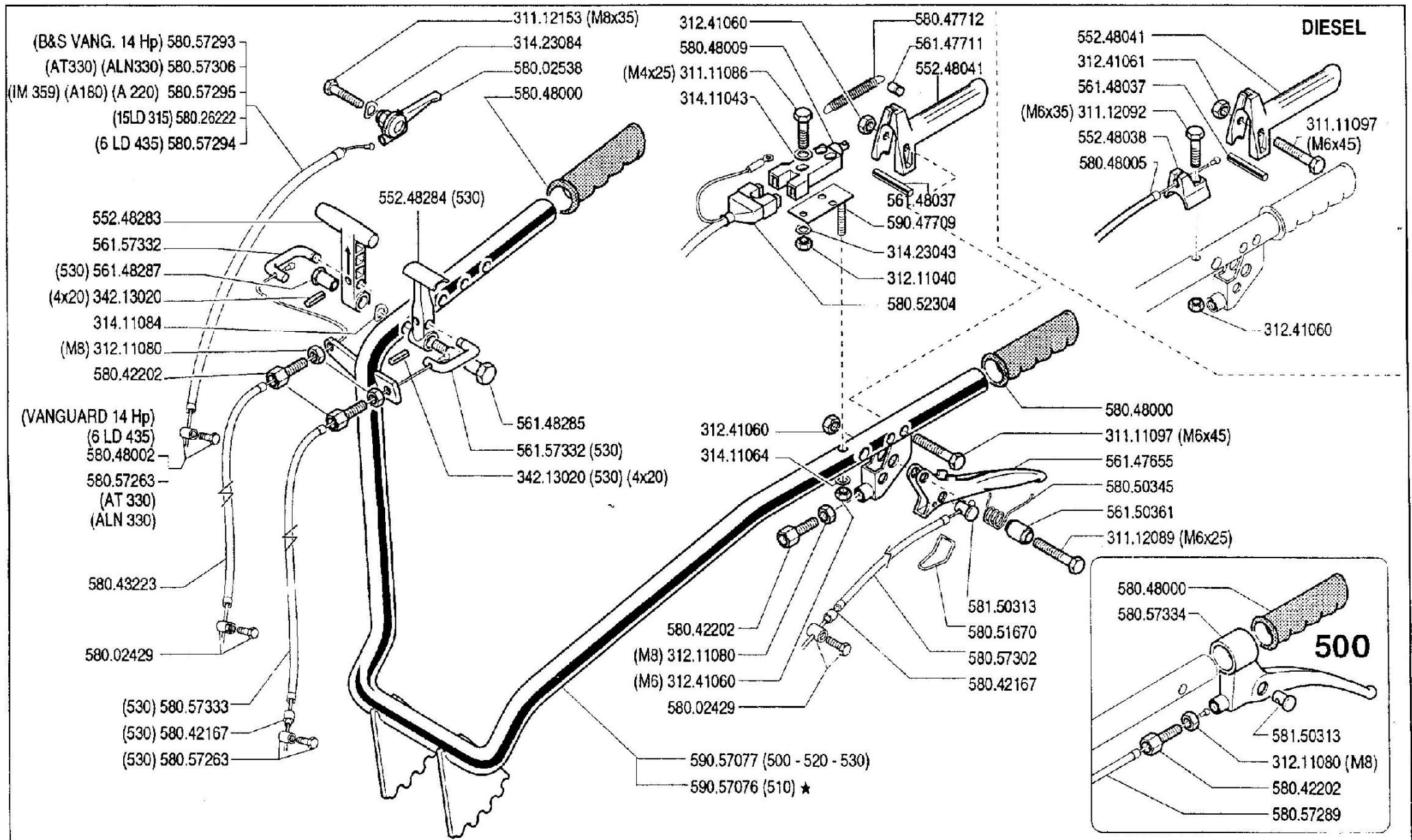

FERRARI

500 serie **95**

MANUBRIO

MANILLAR
 MANCHERON

HANDLEBAR
 LENKER

DALLA MACCHINA
 DE LA MAQUINA
 DE LA MACHINE
 FROM THE MACHINE
 AB DER MASCHINE

AGGIORNAMENTO
 REVISION
 MISE A JOUR
 APLAZAMIENTO
 ANPASSUNG

08.02

9/1997

★ N.

Pos.	Code	Q.ty	Description	Notes
58048002	58048002	0	CLAMPING SCREW	
58048005	58048005	0	LINE AND SHEATH	
58048009	58048009	0	SWITCH	
58050345	58050345	0	SPRING	
58051670	58051670	0	CLEVIS	
58052304	58052304	0	WIRING	
58057263	58057263	0	CLAMPING SCREW	
58057289	58057289	0	LINE AND SHEATH	
58057293	58057293	0	LINE AND SHEATH	
58057294	58057294	0	LINE AND SHEATH	
58057295	58057295	0	LINE AND SHEATH	
58057302	58057302	0	LINE AND SHEATH	
58057306	58057306	0	LINE AND SHEATH	
58057333	58057333	0	LINE AND SHEATH	
58057334	58057334	0	LEVER	
58150313	58150313	0	CABLE CLAMP	
59047709	59047709	0	SWITCH SUPPORT	
59057076	59057076	0	COMPLETE HANDLE BAR	
59057077	59057077	0	COMPLETE HANDLE BAR	

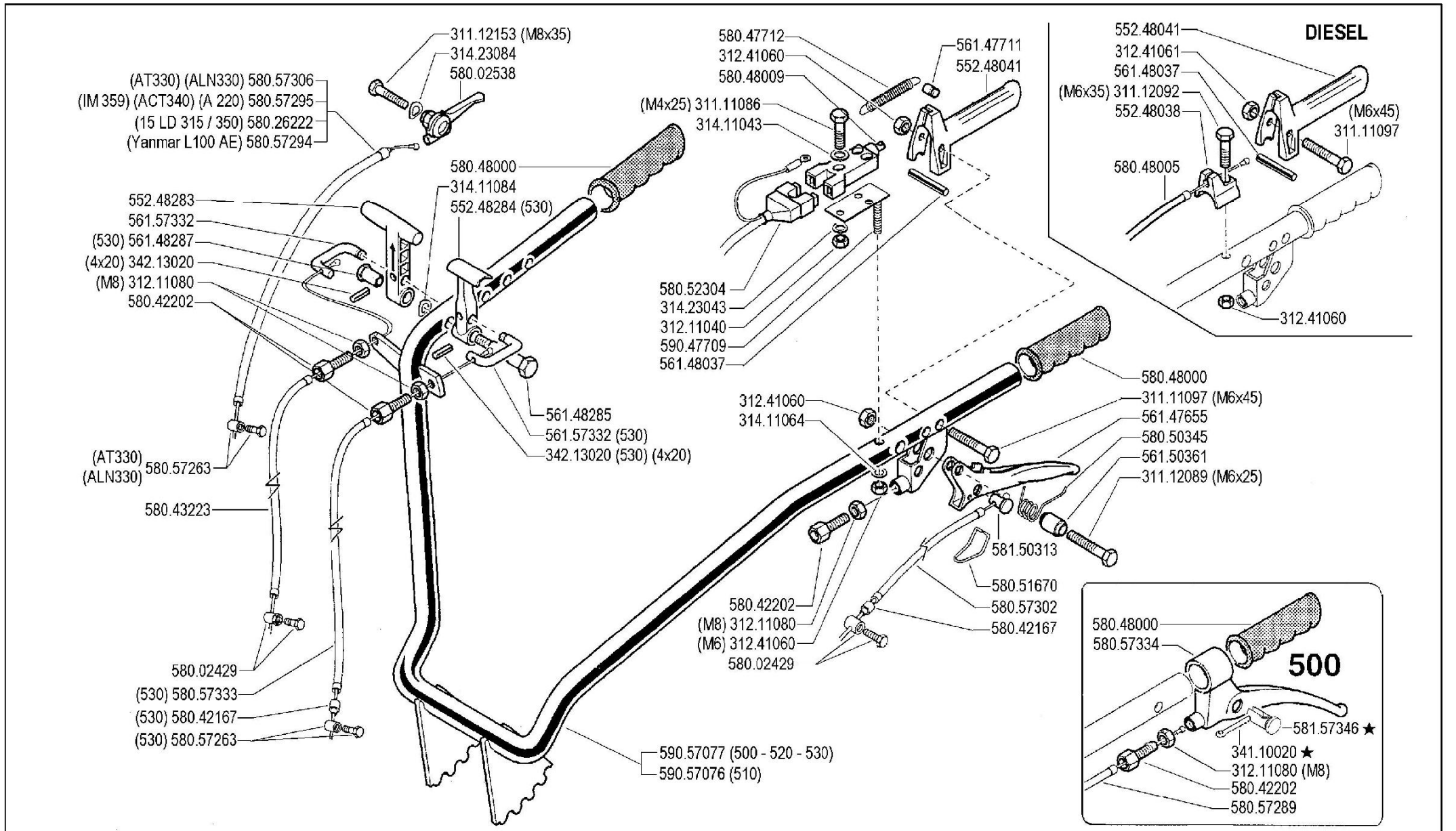

FERRARI

500 serie 95

MANUBRIO (500 - 510 - 520 - 530)

HANDLEBAR
MANILLAR

MANCHERON
LENKER

DALLA MACCHINA
DE LA MAGUINA
DE LA MACHINE
FROM THE MACHINE
AB DER MASCHINE

AGGIORNAMENTO

REVISION

MISE A JOUR

APLAZAMIENTO

ANPASSUNG

08

Mod
03

★N.

1/2000

Pos.	Code	Q.ty	Description	Notes
31111086	31111086	0	SCREW TE M4X25 UNI 5739 8G	
31111097	31111097	0	SCREW TE M6X45 UNI 5737 8G	
31112089	31112089	0	SCREW TE M6X25 UNI 5739 8G	
31112092	31112092	0	SCREW TE M6X35 UNI 5739 8G	
31112153	31112153	0	SCREW TE M8X35 UNI 5739 8G	
31211040	31211040	0	NUT M4	
31211080	31211080	0	NUT M8	
31241060	31241060	0	HEXAGON SELFLOCK NUT M6	
31241061	31241061	0	SELFLOCK NUT M6 6S	
31411043	31411043	0	WASHER 4,3X9	
31411064	31411064	0	WASHER 6,4x12,5	
31411084	31411084	0	WASHER 8,4x17	
31423043	31423043	0	SPRING WASHER 4,3	
31423084	31423084	0	SPRING WASHER 8,4	
34110020	34110020	0	SPLIT PIN	
34213020	34213020	0	ROLL PIN	
55248038	55248038	0	STOP	
55248041	55248041	0	LEVER	
55248283	55248283	0	COMMAND LEVER	
55248284	55248284	0	LEVER	
56147655	56147655	0	CLUTCH LEVER	
56147711	56147711	0	PIN	
56148037	56148037	0	LEVER STOP	
56148285	56148285	0	PIN	
56148287	56148287	0	STUD BOLT	
56150361	56150361	0	SPACER	
56157332	56157332	0	U BOLT	
58002429	58002429	0	CLAMPING SCREW	
58002538	58002538	0	COMMAND LEVER	
58026222	58026222	0	LINE AND SHEATH	
58042167	58042167	0	SHEATH TERMINAL	
58042202	58042202	0	ADJUSTING SCREW	
58043223	58043223	0	LINE AND SHEATH	
58047712	58047712	0	SPRING	

SERIAL

008_03 - HANDLEBAR (500-510-520-530)

CODE REV

008_3_13362

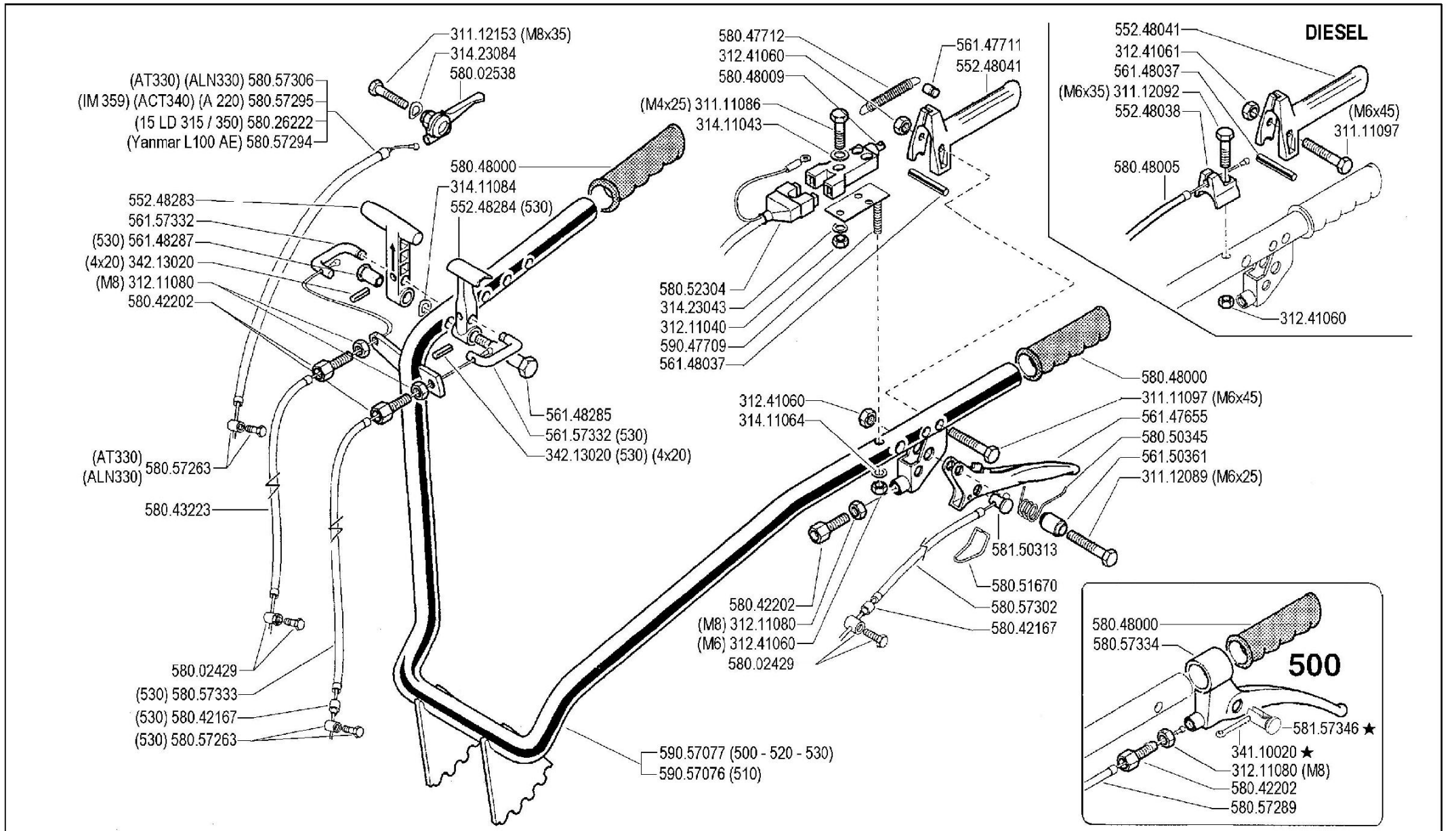

FERRARI

500 serie 95

MANUBRIO (500 - 510 - 520 - 530)

HANDLEBAR
MANILLAR

MANCHERON
LENKER

DALLA MACCHINA
DE LA MAGUINA
DE LA MACHINE
FROM THE MACHINE
AB DER MASCHINE

AGGIORNAMENTO

REVISION

MISE A JOUR

APLAZAMIENTO

ANPASSUNG

08 03

1/2000

★N.

Pos.	Code	Q.ty	Description	Notes
58048000	58048000	0	KNOB	
58048005	58048005	0	LINE AND SHEATH	
58048009	58048009	0	SWITCH	
58050345	58050345	0	SPRING	
58051670	58051670	0	CLEVIS	
58052304	58052304	0	WIRING	
58057263	58057263	0	CLAMPING SCREW	
58057289	58057289	0	LINE AND SHEATH	
58057294	58057294	0	LINE AND SHEATH	
58057295	58057295	0	LINE AND SHEATH	
58057302	58057302	0	LINE AND SHEATH	
58057306	58057306	0	LINE AND SHEATH	
58057333	58057333	0	LINE AND SHEATH	
58057334	58057334	0	LEVER	
58150313	58150313	0	CABLE CLAMP	
58157346	58157346	0	CABLE CLAMP	
59047709	59047709	0	SWITCH SUPPORT	
59057076	59057076	0	COMPLETE HANDLE BAR	
59057077	59057077	0	COMPLETE HANDLE BAR	

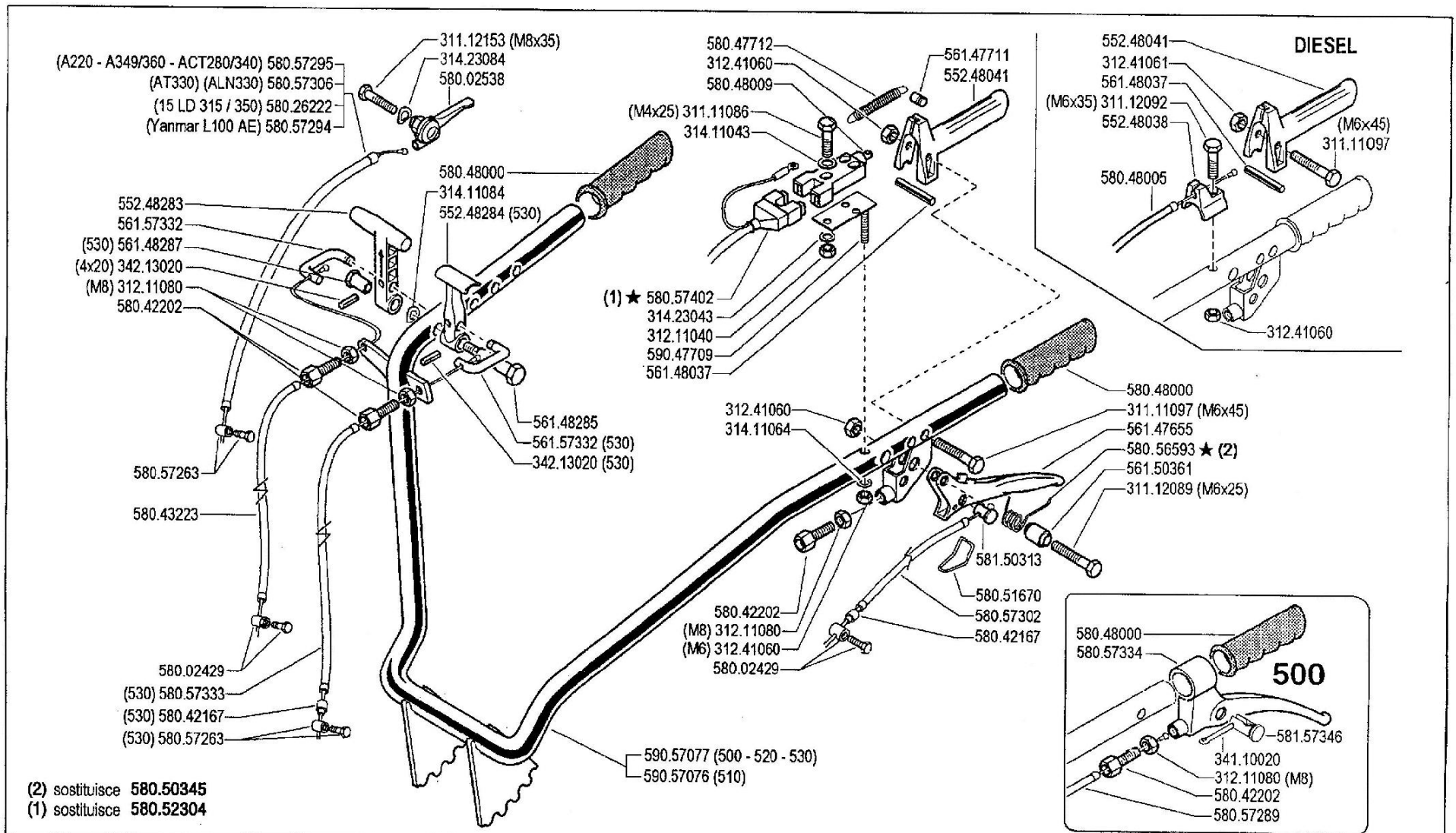

FERRARI

500 serie 95

MANUBRIO (500 - 510 - 520 - 530)

HANDLEBAR
MANILLAR

MANCHERON
LENKER

DALLA MACCHINA
DE LA MAQUINA
DE LA MACHINE
FROM THE MACHINE
AB DER MASCHINE

AGGIORNAMENTO

REVISION

MISE A JOUR

APLAZAMIENTO

ANPASSUNG

08

Rev.
4

11/2002

★N.

ZENNE

Pos.	Code	Q.ty	Description	Notes
31111086	31111086	0	SCREW TE M4X25 UNI 5739 8G	
31111097	31111097	0	SCREW TE M6X45 UNI 5737 8G	
31112089	31112089	0	SCREW TE M6X25 UNI 5739 8G	
31112092	31112092	0	SCREW TE M6X35 UNI 5739 8G	
31112153	31112153	0	SCREW TE M8X35 UNI 5739 8G	
31211040	31211040	0	NUT M4	
31211080	31211080	0	NUT M8	
31241060	31241060	0	HEXAGON SELFLOCK NUT M6	
31241061	31241061	0	SELFLOCK NUT M6 6S	
31411043	31411043	0	WASHER 4,3X9	
31411064	31411064	0	WASHER 6,4x12,5	
31411084	31411084	0	WASHER 8,4x17	
31423043	31423043	0	SPRING WASHER 4,3	
31423084	31423084	0	SPRING WASHER 8,4	
34110020	34110020	0	SPLIT PIN	
34213020	34213020	0	ROLL PIN	
55248038	55248038	0	STOP	
55248041	55248041	0	LEVER	
55248283	55248283	0	COMMAND LEVER	
55248284	55248284	0	LEVER	
56147655	56147655	0	CLUTCH LEVER	
56147711	56147711	0	PIN	
56148037	56148037	0	LEVER STOP	
56148285	56148285	0	PIN	
56148287	56148287	0	STUD BOLT	
56150361	56150361	0	SPACER	
56157332	56157332	0	U BOLT	
58002429	58002429	0	CLAMPING SCREW	
58002538	58002538	0	COMMAND LEVER	
58026222	58026222	0	LINE AND SHEATH	
58042167	58042167	0	SHEATH TERMINAL	
58042202	58042202	0	ADJUSTING SCREW	
58043223	58043223	0	LINE AND SHEATH	
58047712	58047712	0	SPRING	

SERIAL

008_04 - HANDLEBAR (500-510-520-530)

CODE REV

008_4_13416

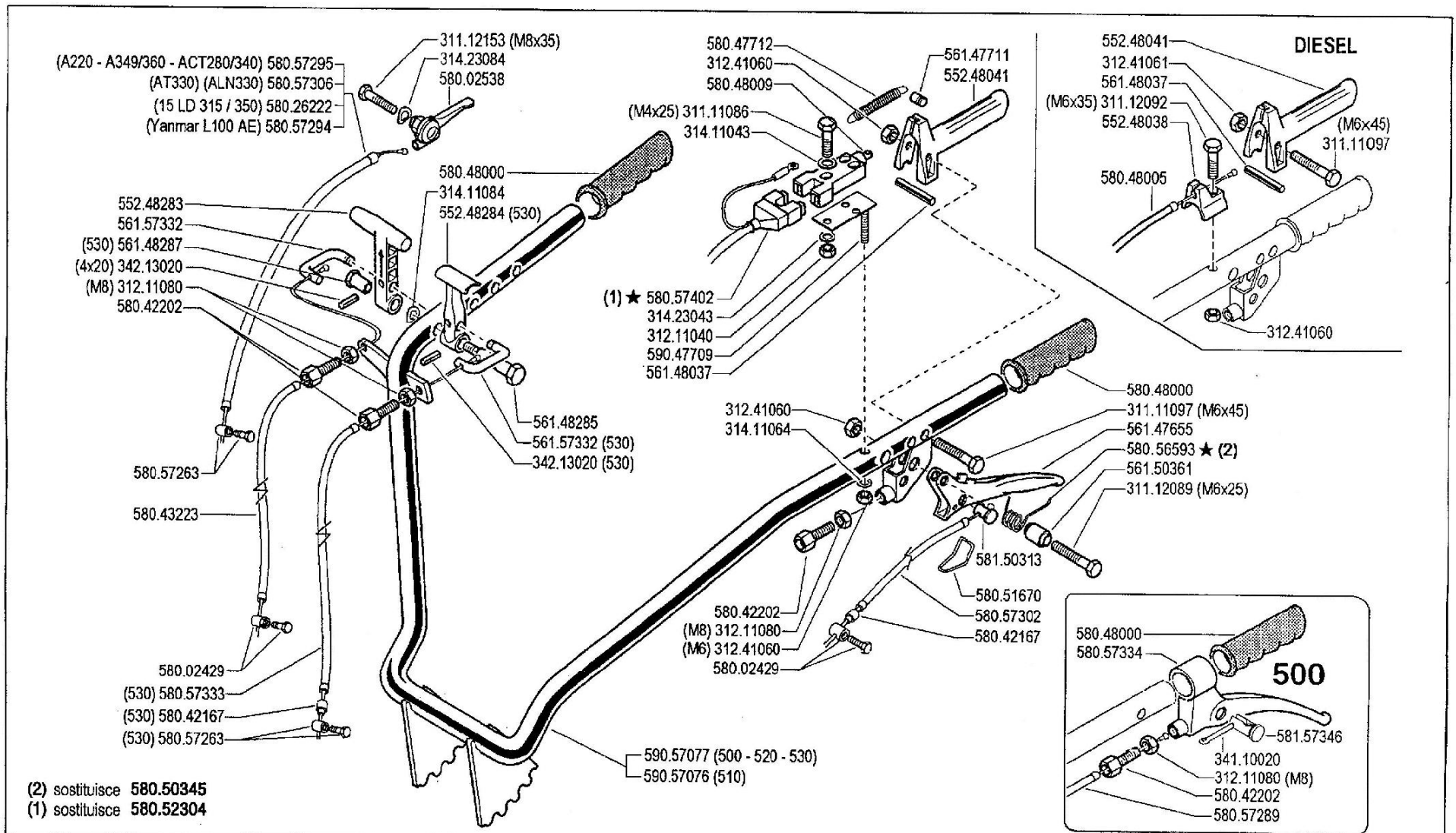

FERRARI

500 serie 95

MANUBRIO (500 - 510 - 520 - 530)

HANDLEBAR
 MANILLAR

MANCHERON
 LENKER

DALLA MACCHINA
 DE LA MAQUINA
 DE LA MACHINE
 FROM THE MACHINE
 AB DER MASCHINE

AGGIORNAMENTO

REVISION

MISE A JOUR

APLAZAMIENTO

ANPASSUNG

08

Rev.
4

11/2002

★N.

ZENNE

Pos.	Code	Q.ty	Description	Notes
58048000	58048000	0	KNOB	
58048005	58048005	0	LINE AND SHEATH	
58048009	58048009	0	SWITCH	
58051670	58051670	0	CLEVIS	
58056593	58056593	0	SPRING	
58057263	58057263	0	CLAMPING SCREW	
58057289	58057289	0	LINE AND SHEATH	
58057294	58057294	0	LINE AND SHEATH	
58057295	58057295	0	LINE AND SHEATH	
58057302	58057302	0	LINE AND SHEATH	
58057306	58057306	0	LINE AND SHEATH	
58057333	58057333	0	LINE AND SHEATH	
58057334	58057334	0	LEVER	
58057402	58057402	0	WIRING	
58150313	58150313	0	CABLE CLAMP	
58157346	58157346	0	CABLE CLAMP	
59047709	59047709	0	SWITCH SUPPORT	
59057076	59057076	0	COMPLETE HANDLE BAR	
59057077	59057077	0	COMPLETE HANDLE BAR	

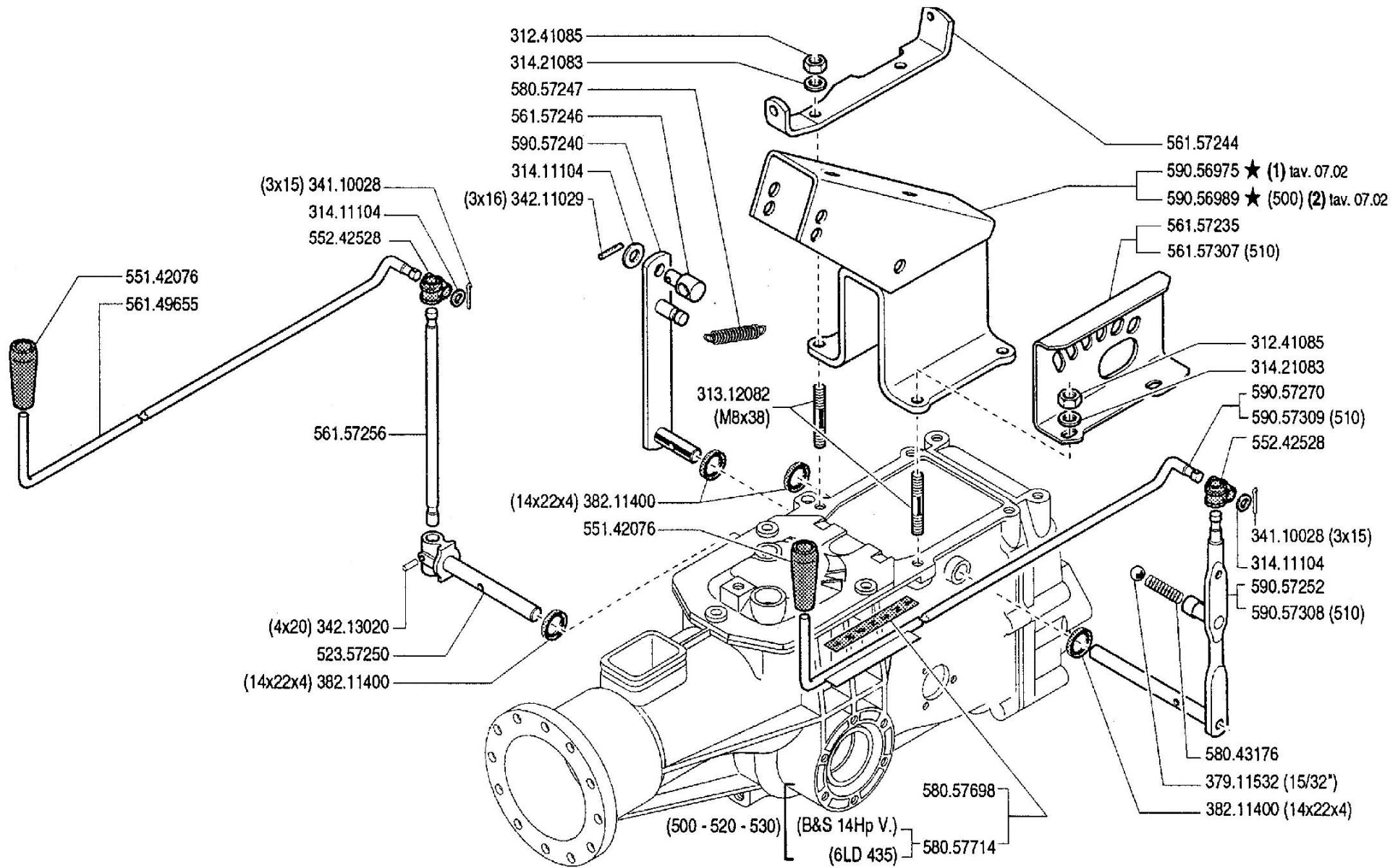

500 serie 95

COMANDI (500-510-520-530)

CONTROLS
MANDOS

COMMANDES
ANTRIEBE

DALLA MACCHINA
DE LA MAQUINA
DE LA MACHINE
FROM THE MACHINE
AB DER MASCHINE

22690 (530)
158833 (520)
★ (510)
80952 (500)

09 02

9/1997

★N.

Pos.	Code	Q.ty	Description	Notes
31241085	31241085	0	SELFLOCK NUT M8 6S	
31312082	31312082	0	STUD BOLT M8X38X14X20	
31411104	31411104	0	WASHER 10,5x18	
31421083	31421083	0	WASHER	
34110028	34110028	0	SPLIT PIN	
34211029	34211029	0	ROLL PIN	
34213020	34213020	0	ROLL PIN	
37911532	37911532	0	BALL 15/32	
38211400	38211400	0	OIL SEAL 14X22X4	
52357250	52357250	0	PIN	
55142076	55142076	0	KNOB	
55242528	55242528	0	JOINT	
56149655	56149655	0	PULL ROD	
56157235	56157235	0	GEAR SELECTOR	
56157244	56157244	0	STOP	
56157246	56157246	0	STOP	
56157256	56157256	0	PTO LEVER	
56157307	56157307	0	SELECTOR	
58043176	58043176	0	SPRING	
58057247	58057247	0	SPRING	
58057698	58057698	0	DECAL	
58057714	58057714	0	DECAL	
59056975	59056975	0	SUPPORT	
59056989	59056989	0	SUPPORT	
59057240	59057240	0	LEVER	
59057252	59057252	0	GEAR LEVER	
59057270	59057270	0	GEARSHIFT ROD	
59057308	59057308	0	GEAR LEVER	
59057309	59057309	0	GEARSHIFT ROD	

SERIAL

009_02 - CONTROLS (500-510-520-530)

Version: MF 510, MF 530, MF 520, MF 500

CODE REV

009_2_13534

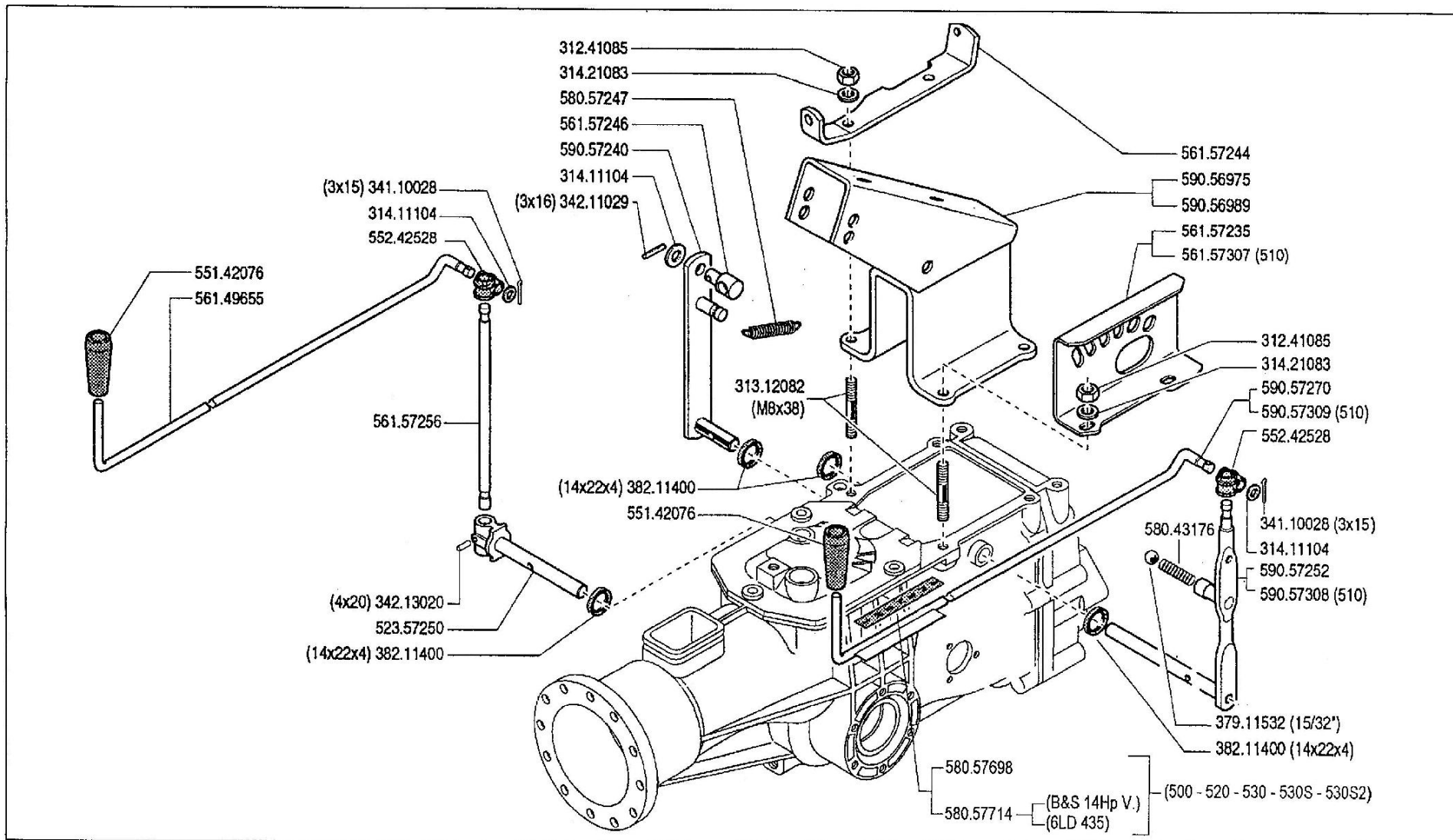

FERRARI

500 serie **95**

COMANDI (500 - 510 - 520 - 530 - 530S★ - 530S2★)

CONTROLS
MANDOS

COMMANDES
ANTRIEBE

DALLA MACCHINA
DE LA MAQUINA
FROM THE MACHINE
AB DER MASCHINE

★N

AGGIORNAMENTO
REVISION
MISE A JOUR
APLAZAMIENTO
ANPASSUNG

09

10/2001

Rev.
3

ZENNE

Pos.	Code	Q.ty	Description	Notes
31241085	31241085	0	SELFLOCK NUT M8 6S	
31312082	31312082	0	STUD BOLT M8X38X14X20	
31411104	31411104	0	WASHER 10,5x18	
31421083	31421083	0	WASHER	
34110028	34110028	0	SPLIT PIN	
34211029	34211029	0	ROLL PIN	
34213020	34213020	0	ROLL PIN	
37911532	37911532	0	BALL 15/32	
38211400	38211400	0	OIL SEAL 14X22X4	
52357250	52357250	0	PIN	
55142076	55142076	0	KNOB	
55242528	55242528	0	JOINT	
56149655	56149655	0	PULL ROD	
56157235	56157235	0	GEAR SELECTOR	
56157244	56157244	0	STOP	
56157246	56157246	0	STOP	
56157256	56157256	0	PTO LEVER	
56157307	56157307	0	SELECTOR	
58043176	58043176	0	SPRING	
58057247	58057247	0	SPRING	
58057698	58057698	0	DECAL	
58057714	58057714	0	DECAL	
59056975	59056975	0	SUPPORT	
59056989	59056989	0	SUPPORT	
59057240	59057240	0	LEVER	
59057252	59057252	0	GEAR LEVER	
59057270	59057270	0	GEARSHIFT ROD	
59057308	59057308	0	GEAR LEVER	
59057309	59057309	0	GEARSHIFT ROD	

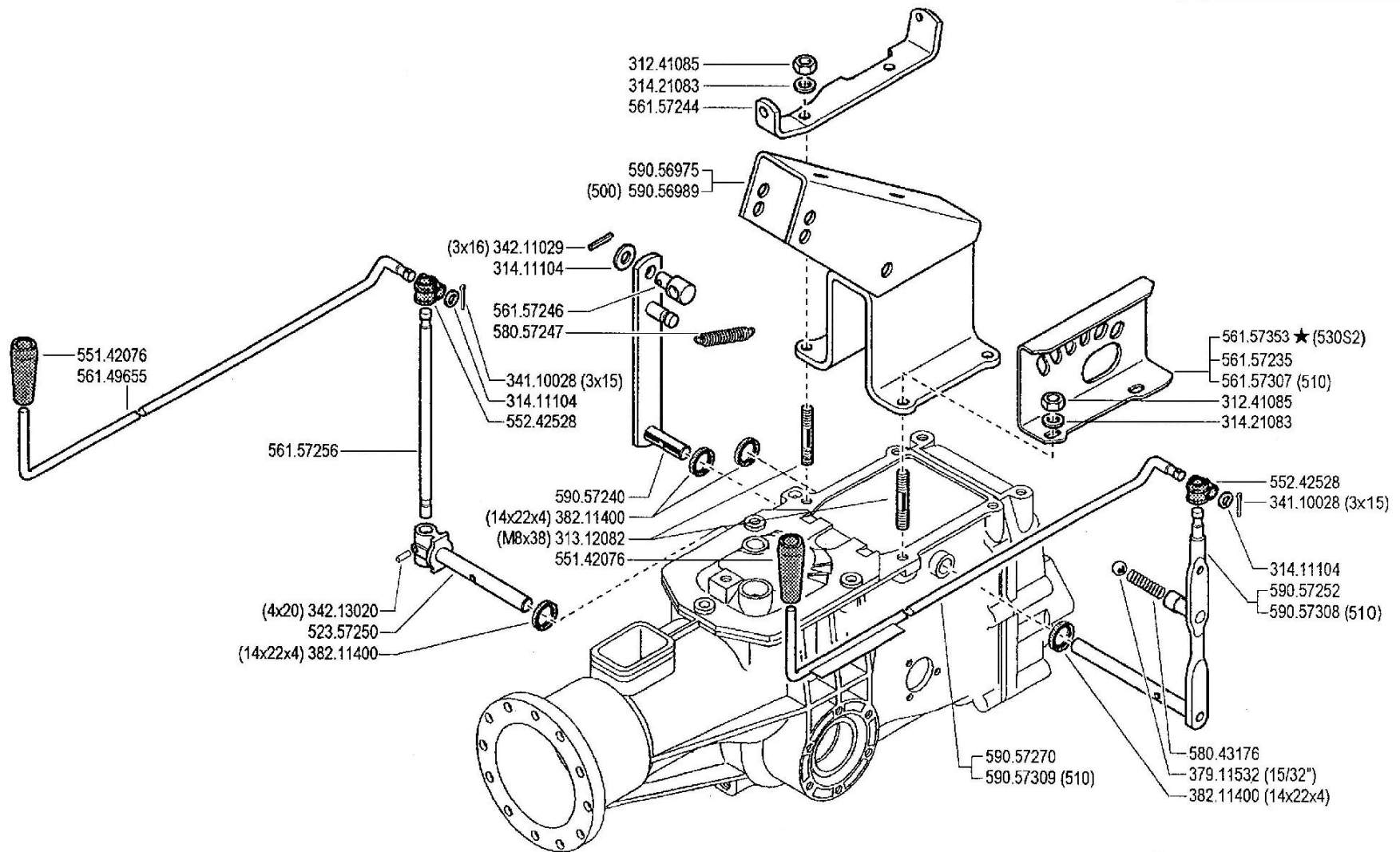

FERRARI

500 serie **95**

COMANDI (500 - 510 - 520 - 530 - 530S2)

CONTROLS
MANDOS

COMMANDES
ANTRIEBE

★ DALLA MACCHINA
DE LA MAQUINA
DE LA MACHINE
FROM THE MACHINE
AB DER MASCHINE

ALLA MACCHINA
A LA MAQUINA
A LA MACHINE
TO THE MACHINE
BIS MASCHINE

09

Rev.
4

N. 721207
721255

721222

1/2004

ZEMME

Pos.	Code	Q.ty	Description	Notes
31241085	31241085	0	SELFLOCK NUT M8 6S	
31312082	31312082	0	STUD BOLT M8X38X14X20	
31411104	31411104	0	WASHER 10,5x18	
31421083	31421083	0	WASHER	
34110028	34110028	0	SPLIT PIN	
34211029	34211029	0	ROLL PIN	
34213020	34213020	0	ROLL PIN	
37911532	37911532	0	BALL 15/32	
38211400	38211400	0	OIL SEAL 14X22X4	
52357250	52357250	0	PIN	
55142076	55142076	0	KNOB	
55242528	55242528	0	JOINT	
56149655	56149655	0	PULL ROD	
56157235	56157235	0	GEAR SELECTOR	
56157244	56157244	0	STOP	
56157246	56157246	0	STOP	
56157256	56157256	0	PTO LEVER	
56157307	56157307	0	SELECTOR	
56157353	56157353	0	GEAR SELECTOR	
58043176	58043176	0	SPRING	
58057247	58057247	0	SPRING	
59056975	59056975	0	SUPPORT	
59056989	59056989	0	SUPPORT	
59057240	59057240	0	LEVER	
59057252	59057252	0	GEAR LEVER	
59057270	59057270	0	GEARSHIFT ROD	
59057308	59057308	0	GEAR LEVER	
59057309	59057309	0	GEARSHIFT ROD	

SERIAL

009_04 - CONTROLS(500/10/20-530-530S2)

CODE REV

009_4_13594

	A	B	C
3.50 - 8" (500)	391.13502	394.13502	580.52325
3.50 - 8"	391.13502	394.13502	580.52326
4.00 - 8"	391.14008	394.14008	580.52326
4.0 - 10"	391.14010	394.14010	580.52327
5.0 - 10"	391.15010	394.15010	580.52327
21 x 11.00 - 8"	391.13501	TUBELESS	580.52274 ★ (1)

★ 924.57794

KIT GEMELLAGGIO PER 4.0-10" / 5.0-10"
 TWINNING KIT FOR 4.0-10" / 5.0-10"
 JUMELAGE KIT POUR 4.0-10" / 5.0-10"
 KIT GEMELOS POR 4.0-10" / 5.0-10"
 ZWILLINGSKIT 4.0-10" / 5.0-10"

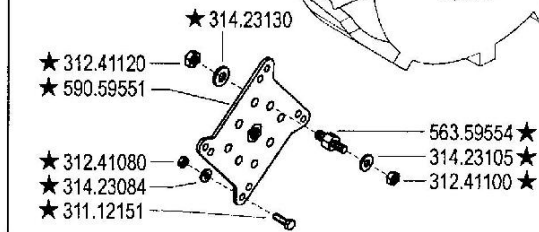
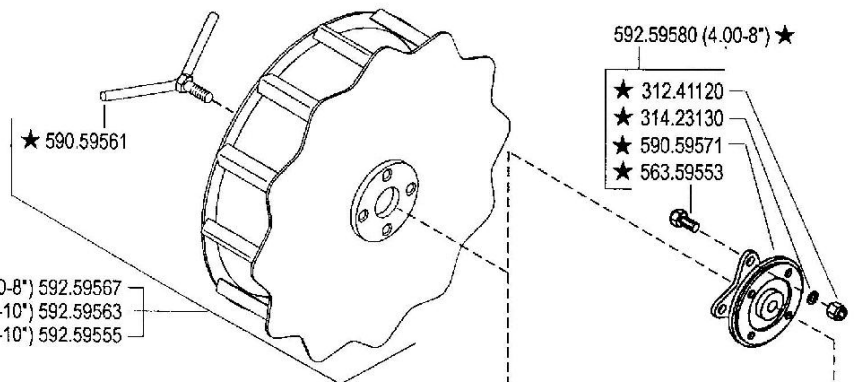
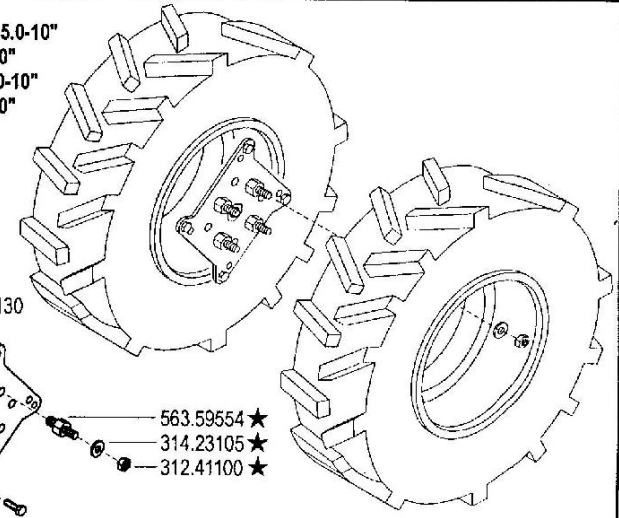

- ★ (4.00-8") 592.59567
- ★ (4.0-10") 592.59563
- ★ (5.0-10") 592.59555

- (4.0-10")
- (5.0-10")
- (21x11.00-8")

- ★ 592.59578
- ★ 563.59553
- ★ 311.12219
- ★ 314.21101
- ★ 311.12151
- ★ 314.23084
- ★ 312.41080
- ★ 314.23084
- ★ 590.59551
- ★ 312.41120
- ★ 314.23130

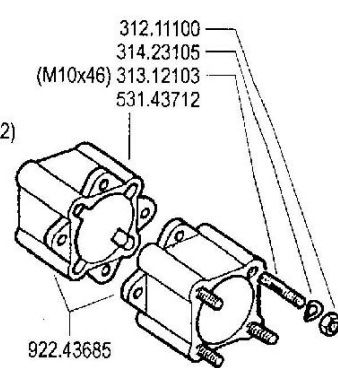
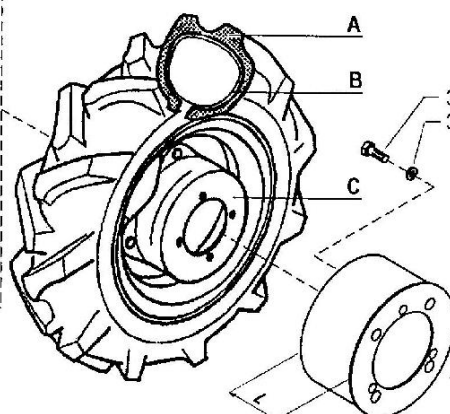

- 590.47745 (L=66)
- 590.47743 (L=126)

(1) sostituisce 580.52331

FERRARI

500 serie 95

RUOTE

WHEELS
RUEDAS

ROUES
RÄDER

DALLA MACCHINA
DE LA MAQUINA
DE LA MACHINE
FROM THE MACHINE
AB DER MASCHINE

AGGIORNAMENTO

REVISION

MISE A JOUR

APLAZAMIENTO

ANPASSUNG

11

Rev.
3

12/2003

★ N

ZENNE

Pos.	Code	Q.ty	Description	Notes
31112149	31112149	0	SCREW TE M8X12 UNI 5739 8G	
31112151	31112151	0	SCREW TE M8X25 UNI 5739 8G	
31112219	31112219	0	SCREW TE M10X25 UNI 5739	
31211100	31211100	0	NUT M10	
31241080	31241080	0	HEXAGON SELFLOCK NUT M8	
31241100	31241100	0	SELFLOCK HEXAGON NUT M10	
31241120	31241120	0	SELFLOCK NUT M12	
31312103	31312103	0	STUD BOLT M10X46X24X16	
31421101	31421101	0	WASHER	
31423084	31423084	0	SPRING WASHER 8,4	
31423105	31423105	0	SPRING WASHER 10,5	
31423130	31423130	0	SPRING WASHER 13	
39113501	39113501	0	TYRE 21X11.00-8	
39113502	39113502	0	TYRE 3.50-8 2PR	
39114008	39114008	0	TYRE 4.00-8 2PR	
39114010	39114010	0	TYRE 4.0-10 2PR	
39115010	39115010	0	TYRE 5.00-10 2PR	
39413502	39413502	0	INNER TUBE	
39414008	39414008	0	INNER TUBE	
39414010	39414010	0	INNER TUBE	
39415010	39415010	0	INNER TUBE	
53143712	53143712	0	SPACER	
56359553	56359553	0	PIN	
56359554	56359554	0	PIN	
58052274	58052274	0	RIM	
58052325	58052325	0	RIM	
58052326	58052326	0	RIM	
58052327	58052327	0	RIM	
59047743	59047743	0	HUBCOVER	
59047745	59047745	0	HUBCOVER	
59059551	59059551	0	FLANGE	
59059561	59059561	0	SCREW	
59059571	59059571	0	FLANGE	
59259555	59259555	0	SUPER-BITE WHEEL X 5.00-10	

SERIAL

W011_03 - HEELS

CODE REV

011_3_13744

	A	B	C
3.50 - 8" (500)	391.13502	394.13502	580.52325
3.50 - 8"	391.13502	394.13502	580.52326
4.00 - 8"	391.14008	394.14008	580.52326
4.0 - 10"	391.14010	394.14010	580.52327
5.0 - 10"	391.15010	394.15010	580.52327
21 x 11.00 - 8"	391.13501	TUBELESS	580.52274 ★ (1)

★ 924.57794

KIT GEMELLAGGIO PER 4.0-10" / 5.0-10"
 TWINNING KIT FOR 4.0-10" / 5.0-10"
 JUMELAGE KIT POUR 4.0-10" / 5.0-10"
 KIT GEMELOS POR 4.0-10" / 5.0-10"
 ZWILLINGSKIT 4.0-10" / 5.0-10"

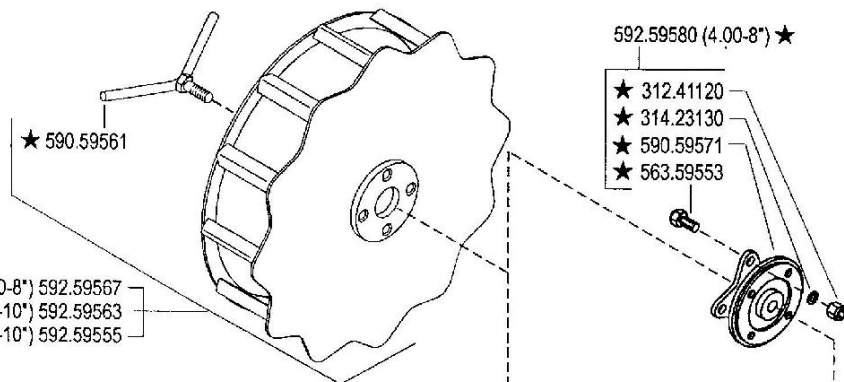
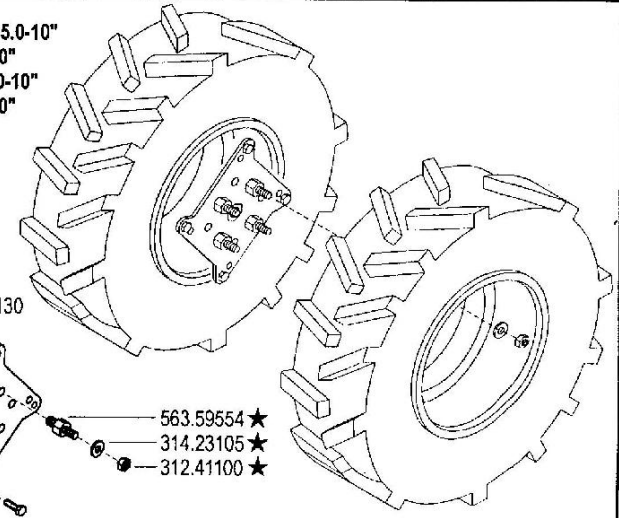

- ★ (4.00-8") 592.59567
- ★ (4.0-10") 592.59563
- ★ (5.0-10") 592.59555

- (4.0-10")
- (5.0-10")
- (21x11.00-8")

- ★ 563.59553
- ★ 311.12219
- ★ 314.21101
- ★ 592.59578
- ★ 312.41080
- ★ 314.23084
- ★ 590.59551
- ★ 312.41120
- ★ 314.23130

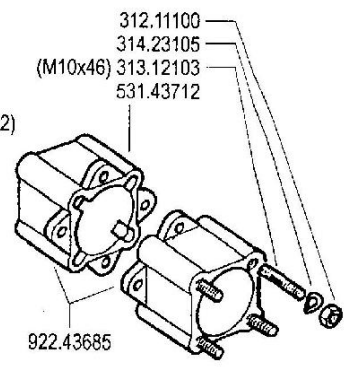
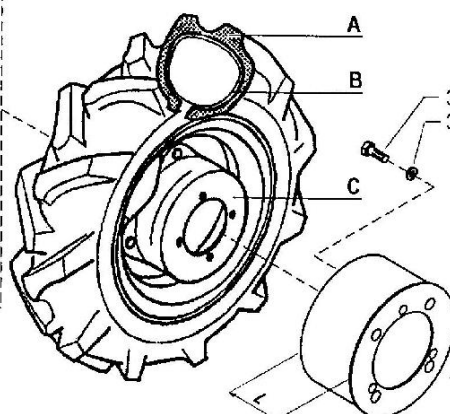

- 590.47745 (L=66)
- 590.47743 (L=126)

(1) sostituisce 580.52331

FERRARI

500 serie 95

RUOTE

WHEELS
RUEDAS

ROUES
RÄDER

DALLA MACCHINA
DE LA MAQUINA
DE LA MACHINE
FROM THE MACHINE
AB DER MASCHINE

AGGIORNAMENTO
REVISION
MISE A JOUR
APLAZAMIENTO
ANPASSUNG

Rev.
11
3
12/2003

★N

ZENNE

Pos.	Code	Q.ty	Description	Notes
59259563	59259563	0	WHEEL	
59259567	59259567	0	WHEEL	
59259578	59259578	0	FLANGE KIT	
59259580	59259580	0	FLANGE KIT	
92243685	92243685	0	PAIR WHEEL SPACERS 6 CM	
92457794	92457794	0	ADAPTOR PLATES 10 WHEELS (PAIR)	

500

580.52018

FERRARI

580.52019

FERRARI

580.52020

520

580.52021

520

580.52022

530

580.52023

530

580.52024

510

580.52033

510

580.52034



580.46901



580.46912

**FRIZIONE
EMBRAYAGE
EMBRAGUE**

580.46903



580.57698



580.57678



580.46913



580.46902



580.46909



580.46910



580.57722

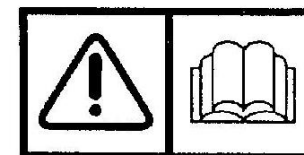

580.57724

FERRARI

500 serie 95

ADHESIVOS
AUTOCOLLANTS

ADESIVI

STICKERS
AUFKLEBES

DALLA MACCHINA
DE LA MAQUINA
DE LA MACHINE
FROM THE MACHINE
AB DER MASCHINE

N.

12.00

9/1997

Pos.	Code	Q.ty	Description	Notes
58046901	58046901	0	DECAL	
58046902	58046902	0	DECAL	
58046903	58046903	0	DECAL	
58046909	58046909	0	DECAL	
58046910	58046910	0	DECAL	
58046912	58046912	0	DECAL	
58046913	58046913	0	DECAL	
58052018	58052018	0	DECAL	
58052019	58052019	0	DECAL	
58052020	58052020	0	DECAL	
58052021	58052021	0	DECAL	
58052022	58052022	0	DECAL	
58052023	58052023	0	DECAL	
58052024	58052024	0	DECAL	
58052033	58052033	0	DECAL	
58052034	58052034	0	DECAL	
58057678	58057678	0	DECAL	
58057698	58057698	0	DECAL	
58057712	58057712	0	DECAL	
58057722	58057722	0	DECAL	
58057724	58057724	0	DECAL	

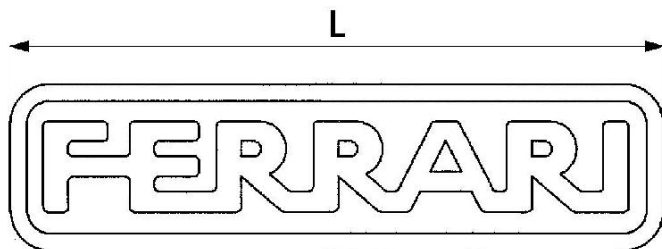

580.52019 (L= 87)
 580.52029 (L= 140) ★
 580.52020 (L= 174)

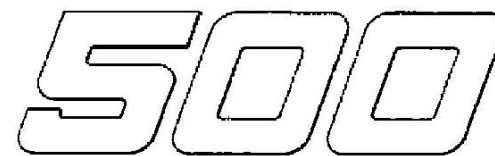

580.52018



580.52033



580.52021



580.52023



580.52034



580.52022



580.52024

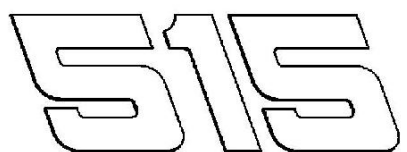

580.52144 ★



580.52146 ★



580.52148 ★



580.52145 ★



580.52147 ★

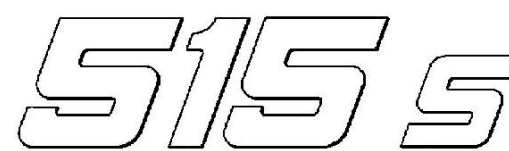

580.52149 ★

FERRARI

500 serie **95**

STICKERS
ADHESIVOS

ADESIVI

AUTOCOLLANTS
AUFKLEBES

DALLA MACCHINA
DE LA MAQUINA
DE LA MACHINE
FROM THE MACHINE
AB DER MASCHINE

★N.

AGGIORNAMENTO

REVISION

MISE A JOUR

APLAZAMIENTO

ANPASSUNG

12

Mod.
01

1/2000

ZENNE

Pos.	Code	Q.ty	Description	Notes
58052018	58052018	0	DECAL	
58052019	58052019	0	DECAL	
58052020	58052020	0	DECAL	
58052021	58052021	0	DECAL	
58052022	58052022	0	DECAL	
58052023	58052023	0	DECAL	
58052024	58052024	0	DECAL	
58052029	58052029	0	DECAL	
58052033	58052033	0	DECAL	
58052034	58052034	0	DECAL	
58052144	58052144	0	DECAL	
58052145	58052145	0	DECAL	
58052146	58052146	0	DECAL	
58052147	58052147	0	DECAL	
58052148	58052148	0	DECAL	
58052149	58052149	0	DECAL	

510

580.52033

510

580.52034

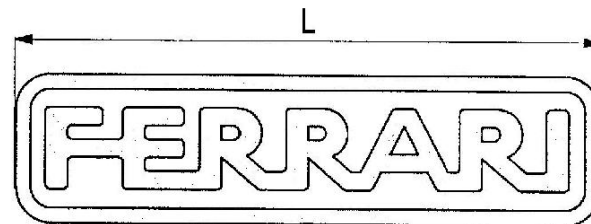

580.52019 (L= 87)
580.52029 (L= 140)
580.52020 (L= 174)

515

580.52144

515

580.52145

520

580.52021

520

580.52022

500

580.52018

530

580.52023

530

580.52024

515 L

580.52146

530 S

580.52150 ★

530 S

580.52151 ★

515 L

580.52147

530 S2

580.52154 ★

530 S2

580.52155 ★

515 S

580.52148

515 S

580.52149

FERRARI

500 serie 95

ADERIVI

STICKERS
ADHESIVOS

AUTOCOLLANTS
AUFKLEBES

DALLA MACCHINA
DE LA MAQUINA
DE LA MACHINE
FROM THE MACHINE
AB DER MASCHINE

AGGIORNAMENTO

REVISION

MISE A JOUR

APLAZAMIENTO

ANPASSUNG

12

Rev.
2

10/2001

★N

ZENIE

Pos.	Code	Q.ty	Description	Notes
58052018	58052018	0	DECAL	
58052019	58052019	0	DECAL	
58052020	58052020	0	DECAL	
58052021	58052021	0	DECAL	
58052022	58052022	0	DECAL	
58052023	58052023	0	DECAL	
58052024	58052024	0	DECAL	
58052029	58052029	0	DECAL	
58052033	58052033	0	DECAL	
58052034	58052034	0	DECAL	
58052144	58052144	0	DECAL	
58052145	58052145	0	DECAL	
58052146	58052146	0	DECAL	
58052147	58052147	0	DECAL	
58052148	58052148	0	DECAL	
58052149	58052149	0	DECAL	
58052150	58052150	0	DECAL	
58052151	58052151	0	DECAL	
58052154	58052154	0	DECAL	
58052155	58052155	0	DECAL	

4

N

3

N

2

N

1

580.57698

PERICOLO DI RIBALZAMENTO
DANGER DE CAPOTAGE
DANGER OF UPSETTING
UEBERSCHLAGENSFAHR
PELIGRO DE VUELCO

580.57722

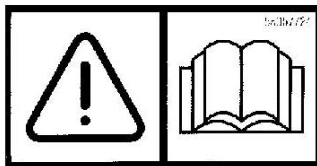

580.57724

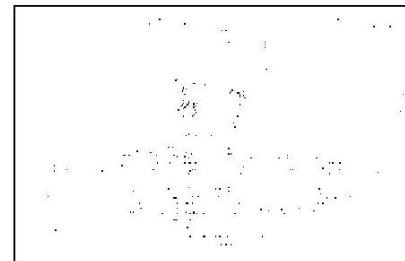

580.46909

N



580.57712

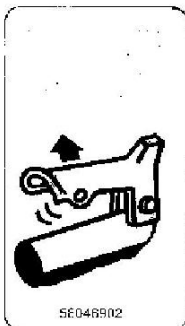

580.46902

**ATTENZIONE - ATTENTION
ATENCIÓN**

LA ZONA DEL TUBO DI SCARICO PUO' SUPERARE 65 °C
LA ZONE DU TUBAU D'ECHAPPEMENT PEUT DEPASSE 65 °C
LA ZONA DEL TUBO DE ESCAPE PUEDE SUPERAR LOS 65 °C

580.46910

580.57698



580.57678

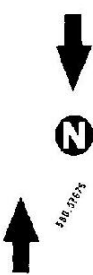

580.57676 ★



580.46901

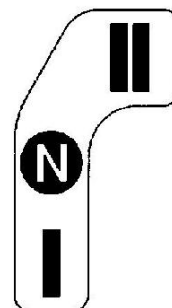

580.57732 ★

**FRIZIONE
EMBAYAGE
EMBRAGUE**

580.46903

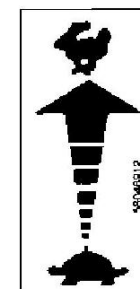

580.46912



580.46913

FERRARI

500 serie 95

ADESIVI

STICKERS
ADHESIVOS

AUTOCOLLANTS
AUFKLEBES

DALLA MACCHINA
DE LA MAQUINA
DE LA MACHINE
FROM THE MACHINE
AB DER MASCHINE

★ N.

13 00

1/2000

ZENNE

Pos.	Code	Q.ty	Description	Notes
58046901	58046901	0	DECAL	
58046902	58046902	0	DECAL	
58046903	58046903	0	DECAL	
58046909	58046909	0	DECAL	
58046910	58046910	0	DECAL	
58046912	58046912	0	DECAL	
58046913	58046913	0	DECAL	
58057676	58057676	0	DECAL	
58057678	58057678	0	DECAL	
58057698	58057698	0	DECAL	
58057712	58057712	0	DECAL	
58057722	58057722	0	DECAL	
58057724	58057724	0	DECAL	
58057732	58057732	0	DECAL	



580.57698

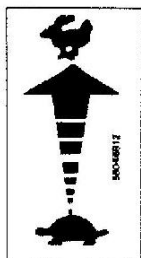

580.46912



580.46913

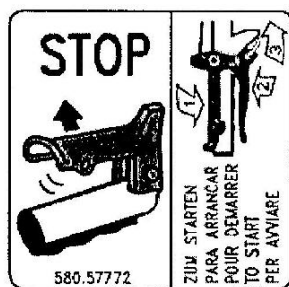

580.57772 ★

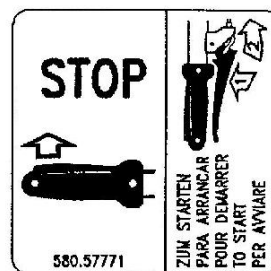

580.57771 ★



580.57767 ★

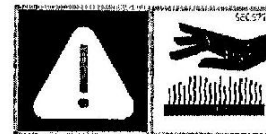

580.57768 ★



580.57678



580.57712



580.57676

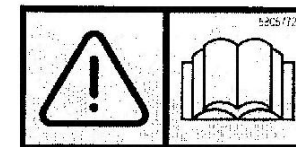

580.57724



580.57770 ★



580.57722

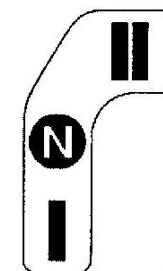

580.57732

FERRARI

500 serie 95

ADESIVI

STICKERS
ADHESIVOS

AUTOCOLLANTS
AUFKLEBES

DALLA MACCHINA
DE LA MAQUINA
DE LA MACHINE
FROM THE MACHINE
AB DER MASCHINE

AGGIORNAMENTO

REVISION

MISE A JOUR

APLAZAMIENTO

ANPASSUNG

13

Rev.
1

12/2003

★N

ZENNE

Pos.	Code	Q.ty	Description	Notes
58046912	58046912	0	DECAL	
58046913	58046913	0	DECAL	
58057676	58057676	0	DECAL	
58057678	58057678	0	DECAL	
58057698	58057698	0	DECAL	
58057712	58057712	0	DECAL	
58057722	58057722	0	DECAL	
58057724	58057724	0	DECAL	
58057732	58057732	0	DECAL	
58057767	58057767	0	DECAL	
58057768	58057768	0	DECAL	
58057770	58057770	0	DECAL	
58057771	58057771	0	DECAL	
58057772	58057772	0	DECAL	

SPARE PARTS INSTANCE INDEX





SPARE PARTS INSTANCE INDEX

Code	Parts Table	Pos.	Q.ty	Code	Parts Table	Pos.	Q.ty	Code	Parts Table	Pos.	Q.ty
3000628	001_2_12649	3000628	0	31112092	008_4_13416	31112092	0	31211040	008_2_13308	31211040	0
30010120	007_2_13157	30010120	0	31112147	005_2_13039	31112147	0		008_3_13362	31211040	0
	007_3_13177	30010120	0	31112149	011_3_13744	31112149	0		008_4_13416	31211040	0
30040001	03A_0_13890	30040001	0	31112150	001_2_12649	31112150	0	31211080	002_0_12722	31211080	0
	03A_1_13913	30040001	0		001_3_12676	31112150	0		002_1_12741	31211080	0
30040133	03A_0_13890	30040133	0		001_4_12698	31112150	0		002_2_12761	31211080	0
	03A_1_13913	30040133	0	31112151	011_3_13744	31112151	0		002_3_12779	31211080	0
31100003	002_2_12761	31100003	0	31112152	03A_0_13890	31112152	0		007_2_13157	31211080	0
	002_3_12779	31100003	0		03A_1_13913	31112152	0		008_2_13308	31211080	0
31100015	002_0_12722	31100015	0	31112153	007_2_13157	31112153	0		008_3_13362	31211080	0
	002_1_12741	31100015	0		007_3_13177	31112153	0		008_4_13416	31211080	0
	002_3_12779	31100015	0		008_2_13308	31112153	0	31211100	005_1_13022	31211100	0
31100786	002_0_12722	31100786	0		008_3_13362	31112153	0		005_2_13039	31211100	0
	002_1_12741	31100786	0		008_4_13416	31112153	0		011_3_13744	31211100	0
	002_2_12761	31100786	0	31112154	001_2_12649	31112154	0	31221121	03A_0_13890	31221121	0
	002_3_12779	31100786	0		001_3_12676	31112154	0		03A_1_13913	31221121	0
31111086	008_2_13308	31111086	0		001_4_12698	31112154	0	31241060	008_2_13308	31241060	0
	008_3_13362	31111086	0	31112210	03A_1_13913	31112210	0		008_3_13362	31241060	0
	008_4_13416	31111086	0	31112211	007_2_13157	31112211	0		008_4_13416	31241060	0
31111090	001_2_12649	31111090	0		007_3_13177	31112211	0	31241061	008_2_13308	31241061	0
	03A_1_13913	31111090	0	31112213	001_2_12649	31112213	0		008_3_13362	31241061	0
31111097	008_2_13308	31111097	0		001_3_12676	31112213	0		008_4_13416	31241061	0
	008_3_13362	31111097	0		001_4_12698	31112213	0	31241080	001_2_12649	31241080	0
	008_4_13416	31111097	0	31112219	011_3_13744	31112219	0		001_3_12676	31241080	0
31111151	001_2_12649	31111151	0	31112295	007_2_13157	31112295	0		001_4_12698	31241080	0
	001_3_12676	31111151	0		007_3_13177	31112295	0		007_2_13157	31241080	0
	001_4_12698	31111151	0	31121007	001_2_12649	31121007	0		007_3_13177	31241080	0
31111229	007_2_13157	31111229	0		001_3_12676	31121007	0		011_3_13744	31241080	0
	007_3_13177	31111229	0		001_4_12698	31121007	0		03A_0_13890	31241080	0
31112089	008_2_13308	31112089	0	31132562	03A_0_13890	31132562	0		03A_1_13913	31241080	0
	008_3_13362	31112089	0		03A_1_13913	31132562	0	31241085	009_2_13534	31241085	0
	008_4_13416	31112089	0	31152060	02A_0_13875	31152060	0		009_3_13564	31241085	0
31112092	008_2_13308	31112092	0	31152085	02A_0_13875	31152085	0		009_4_13594	31241085	0
	008_3_13362	31112092	0	31152103	03A_1_13913	31152103	0		03A_0_13890	31241085	0

SPARE PARTS INSTANCE INDEX

Code	Parts Table	Pos.	Q.ty	Code	Parts Table	Pos.	Q.ty	Code	Parts Table	Pos.	Q.ty
31241085	03A_1_13913	31241085	0	31411043	008_2_13308	31411043	0	31423043	008_3_13362	31423043	0
31241100	001_2_12649	31241100	0		008_3_13362	31411043	0		008_4_13416	31423043	0
	001_3_12676	31241100	0		008_4_13416	31411043	0	31423084	001_2_12649	31423084	0
	001_4_12698	31241100	0	31411064	001_2_12649	31411064	0		001_3_12676	31423084	0
	007_2_13157	31241100	0		008_2_13308	31411064	0		001_4_12698	31423084	0
	007_3_13177	31241100	0		008_3_13362	31411064	0		002_0_12722	31423084	0
	011_3_13744	31241100	0		008_4_13416	31411064	0		002_1_12741	31423084	0
31241120	005_1_13022	31241120	0	31411084	001_2_12649	31411084	0		002_2_12761	31423084	0
	005_2_13039	31241120	0		001_3_12676	31411084	0		002_3_12779	31423084	0
	011_3_13744	31241120	0		001_4_12698	31411084	0		007_2_13157	31423084	0
31241121	007_2_13157	31241121	0		008_2_13308	31411084	0		007_3_13177	31423084	0
	007_3_13177	31241121	0		008_3_13362	31411084	0		008_2_13308	31423084	0
31312082	009_2_13534	31312082	0		008_4_13416	31411084	0		008_3_13362	31423084	0
	009_3_13564	31312082	0	31411104	001_2_12649	31411104	0		008_4_13416	31423084	0
	009_4_13594	31312082	0		001_3_12676	31411104	0		011_3_13744	31423084	0
	03A_0_13890	31312082	0		001_4_12698	31411104	0		03A_0_13890	31423084	0
	03A_1_13913	31312082	0		009_2_13534	31411104	0		03A_1_13913	31423084	0
31312083	002_1_12741	31312083	0		009_3_13564	31411104	0	31423105	002_0_12722	31423105	0
	002_2_12761	31312083	0		009_4_13594	31411104	0		002_1_12741	31423105	0
	002_3_12779	31312083	0	31421083	001_2_12649	31421083	0		002_3_12779	31423105	0
31312086	03A_0_13890	31312086	0		001_3_12676	31421083	0		005_1_13022	31423105	0
	03A_1_13913	31312086	0		001_4_12698	31421083	0		005_2_13039	31423105	0
31312088	002_0_12722	31312088	0		009_2_13534	31421083	0		011_3_13744	31423105	0
	002_1_12741	31312088	0		009_3_13564	31421083	0	31423130	007_2_13157	31423130	0
	002_2_12761	31312088	0		009_4_13594	31421083	0		007_3_13177	31423130	0
	002_3_12779	31312088	0		03A_0_13890	31421083	0		011_3_13744	31423130	0
31312094	03A_0_13890	31312094	0		03A_1_13913	31421083	0		03A_0_13890	31423130	0
	03A_1_13913	31312094	0	31421101	011_3_13744	31421101	0		03A_1_13913	31423130	0
31312102	005_1_13022	31312102	0		03A_1_13913	31421101	0	31424084	005_2_13039	31424084	0
	005_2_13039	31312102	0	31421130	005_1_13022	31421130	0	34110020	008_3_13362	34110020	0
31312103	011_3_13744	31312103	0		005_2_13039	31421130	0		008_4_13416	34110020	0
31312124	03A_0_13890	31312124	0	31422064	02A_0_13875	31422064	0	34110028	009_2_13534	34110028	0
	03A_1_13913	31312124	0		03A_1_13913	31422064	0		009_3_13564	34110028	0
31312125	03A_1_13913	31312125	0	31423043	008_2_13308	31423043	0		009_4_13594	34110028	0



SPARE PARTS INSTANCE INDEX

Code	Parts Table	Pos.	Q.ty	Code	Parts Table	Pos.	Q.ty	Code	Parts Table	Pos.	Q.ty
34211025	04A_0_14000	34211025	0	37111250	04A_1_14034	37111250	0	39413502	011_3_13744	39413502	0
	04A_1_14034	34211025	0	37112171	02A_0_13875	37112171	0	39414008	011_3_13744	39414008	0
34211029	009_2_13534	34211029	0	37112173	002_0_12722	37112173	0	39414010	011_3_13744	39414010	0
	009_3_13564	34211029	0		002_1_12741	37112173	0	39415010	011_3_13744	39415010	0
	009_4_13594	34211029	0		002_2_12761	37112173	0	50947833	002_0_12722	50947833	0
34213020	008_2_13308	34213020	0		002_3_12779	37112173	0		002_1_12741	50947833	0
	008_3_13362	34213020	0	37112229	04A_0_14000	37112229	0		002_2_12761	50947833	0
	008_4_13416	34213020	0		04A_1_14034	37112229	0		002_3_12779	50947833	0
	009_2_13534	34213020	0	37112231	002_2_12761	37112231	0	52148105	02A_0_13875	52148105	0
	009_3_13564	34213020	0		002_3_12779	37112231	0	52357250	009_2_13534	52357250	0
	009_4_13594	34213020	0	37112233	002_0_12722	37112233	0		009_3_13564	52357250	0
34213060	04A_0_14000	34213060	0		002_1_12741	37112233	0		009_4_13594	52357250	0
	04A_1_14034	34213060	0		002_3_12779	37112233	0	52447896	002_0_12722	52447896	0
34213061	04A_0_14000	34213061	0	37320120	04A_0_14000	37320120	0		002_1_12741	52447896	0
	04A_1_14034	34213061	0		04A_1_14034	37320120	0		002_2_12761	52447896	0
34311060	005_1_13022	34311060	0	37910832	04A_0_14000	37910832	0		002_3_12779	52447896	0
	005_2_13039	34311060	0		04A_1_14034	37910832	0	52456335	04A_0_14000	52456335	0
35111052	005_1_13022	35111052	0	37911532	009_2_13534	37911532	0		04A_1_14034	52456335	0
	005_2_13039	35111052	0		009_3_13564	37911532	0	52456339	04A_0_14000	52456339	0
	04A_0_14000	35111052	0		009_4_13594	37911532	0		04A_1_14034	52456339	0
	04A_1_14034	35111052	0	38211400	009_2_13534	38211400	0	52456354	04A_0_14000	52456354	0
35111055	04A_0_14000	35111055	0		009_3_13564	38211400	0		04A_1_14034	52456354	0
	04A_1_14034	35111055	0		009_4_13594	38211400	0	52456356	04A_0_14000	52456356	0
35121031	04A_0_14000	35121031	0	38211500	04A_0_14000	38211500	0		04A_1_14034	52456356	0
	04A_1_14034	35121031	0		04A_1_14034	38211500	0	52456362	04A_0_14000	52456362	0
35211120	04A_0_14000	35211120	0	38212501	005_1_13022	38212501	0		04A_1_14034	52456362	0
	04A_1_14034	35211120	0		005_2_13039	38212501	0	52456389	04A_0_14000	52456389	0
37111150	04A_0_14000	37111150	0	38213800	04A_0_14000	38213800	0		04A_1_14034	52456389	0
	04A_1_14034	37111150	0		04A_1_14034	38213800	0	52456390	04A_0_14000	52456390	0
37111152	04A_0_14000	37111152	0	39113501	011_3_13744	39113501	0		04A_1_14034	52456390	0
	04A_1_14034	37111152	0	39113502	011_3_13744	39113502	0	53143128	03A_1_13913	53143128	0
37111250	005_1_13022	37111250	0	39114008	011_3_13744	39114008	0	53143712	011_3_13744	53143712	0
	005_2_13039	37111250	0	39114010	011_3_13744	39114010	0	53143879	03A_0_13890	53143879	0
	04A_0_14000	37111250	0	39115010	011_3_13744	39115010	0		03A_1_13913	53143879	0



SPARE PARTS INSTANCE INDEX

Code	Parts Table	Pos.	Q.ty	Code	Parts Table	Pos.	Q.ty	Code	Parts Table	Pos.	Q.ty
53147482	002_0_12722	53147482	0	55243592	005_1_13022	55243592	0	56147845	002_1_12741	56147845	0
	002_1_12741	53147482	0		005_2_13039	55243592	0		002_2_12761	56147845	0
53148107	02A_0_13875	53148107	0	55248038	008_2_13308	55248038	0		002_3_12779	56147845	0
53156150	002_3_12779	53156150	0		008_3_13362	55248038	0	56147923	03A_1_13913	56147923	0
53156325	03A_0_13890	53156325	0		008_4_13416	55248038	0	56148037	008_2_13308	56148037	0
	03A_1_13913	53156325	0	55248041	008_2_13308	55248041	0		008_3_13362	56148037	0
53156332	03A_0_13890	53156332	0		008_3_13362	55248041	0		008_4_13416	56148037	0
	03A_1_13913	53156332	0		008_4_13416	55248041	0	56148285	008_2_13308	56148285	0
53156342	03A_0_13890	53156342	0	55248283	008_2_13308	55248283	0		008_3_13362	56148285	0
	03A_1_13913	53156342	0		008_3_13362	55248283	0		008_4_13416	56148285	0
53247468	002_2_12761	53247468	0		008_4_13416	55248283	0	56148287	008_2_13308	56148287	0
53247488	002_3_12779	53247488	0	55248284	008_2_13308	55248284	0		008_3_13362	56148287	0
54143090	005_1_13022	54143090	0		008_3_13362	55248284	0		008_4_13416	56148287	0
	005_2_13039	54143090	0		008_4_13416	55248284	0	56149655	009_2_13534	56149655	0
54143149	005_1_13022	54143149	0	55252316	001_2_12649	55252316	0		009_3_13564	56149655	0
	005_2_13039	54143149	0		001_3_12676	55252316	0		009_4_13594	56149655	0
55102678	03A_0_13890	55102678	0		001_4_12698	55252316	0	56150361	008_2_13308	56150361	0
	03A_1_13913	55102678	0	56120364	007_2_13157	56120364	0		008_3_13362	56150361	0
55102714	007_2_13157	55102714	0		007_3_13177	56120364	0		008_4_13416	56150361	0
	007_3_13177	55102714	0	56142314	005_1_13022	56142314	0	56152241	001_2_12649	56152241	0
55142076	009_2_13534	55142076	0		005_2_13039	56142314	0		001_3_12676	56152241	0
	009_3_13564	55142076	0	56143059	005_1_13022	56143059	0		001_4_12698	56152241	0
	009_4_13594	55142076	0		005_2_13039	56143059	0	56156119	001_4_12698	56156119	0
55147842	002_0_12722	55147842	0	56143121	02A_0_13875	56143121	0	56156152	001_2_12649	56156152	0
	002_1_12741	55147842	0	56143122	02A_0_13875	56143122	0	56156487	005_2_13039	56156487	0
	002_2_12761	55147842	0	56147499	001_2_12649	56147499	0	56156488	005_2_13039	56156488	0
	002_3_12779	55147842	0	56147520	03A_1_13913	56147520	0	56156940	007_2_13157	56156940	0
55220363	007_2_13157	55220363	0	56147655	008_2_13308	56147655	0		007_3_13177	56156940	0
	007_3_13177	55220363	0		008_3_13362	56147655	0	56156948	007_3_13177	56156948	0
55242528	009_2_13534	55242528	0		008_4_13416	56147655	0	56157235	009_2_13534	56157235	0
	009_3_13564	55242528	0	56147711	008_2_13308	56147711	0		009_3_13564	56157235	0
	009_4_13594	55242528	0		008_3_13362	56147711	0		009_4_13594	56157235	0
55243340	007_2_13157	55243340	0		008_4_13416	56147711	0	56157244	009_2_13534	56157244	0
	007_3_13177	55243340	0	56147845	002_0_12722	56147845	0		009_3_13564	56157244	0



SPARE PARTS INSTANCE INDEX

Code	Parts Table	Pos.	Q.ty	Code	Parts Table	Pos.	Q.ty	Code	Parts Table	Pos.	Q.ty
56157244	009_4_13594	56157244	0	56356331	04A_1_14034	56356331	0	58043176	009_2_13534	58043176	0
56157246	009_2_13534	56157246	0	56356348	04A_0_14000	56356348	0		009_3_13564	58043176	0
	009_3_13564	56157246	0		04A_1_14034	56356348	0		009_4_13594	58043176	0
	009_4_13594	56157246	0	56359553	011_3_13744	56359553	0	58043223	008_2_13308	58043223	0
56157256	009_2_13534	56157256	0	56359554	011_3_13744	56359554	0		008_3_13362	58043223	0
	009_3_13564	56157256	0	56456347	04A_0_14000	56456347	0		008_4_13416	58043223	0
	009_4_13594	56157256	0		04A_1_14034	56456347	0	58046901	012_0_13785	58046901	0
56157307	009_2_13534	56157307	0	56456350	04A_0_14000	56456350	0		013_0_13845	58046901	0
	009_3_13564	56157307	0		04A_1_14034	56456350	0	58046902	012_0_13785	58046902	0
	009_4_13594	56157307	0	56456475	04A_0_14000	56456475	0		013_0_13845	58046902	0
56157332	008_2_13308	56157332	0		04A_1_14034	56456475	0	58046903	012_0_13785	58046903	0
	008_3_13362	56157332	0	58002429	008_2_13308	58002429	0		013_0_13845	58046903	0
	008_4_13416	56157332	0		008_3_13362	58002429	0	58046909	012_0_13785	58046909	0
56157353	009_4_13594	56157353	0		008_4_13416	58002429	0		013_0_13845	58046909	0
56243113	02A_0_13875	56243113	0	58002538	008_2_13308	58002538	0	58046910	012_0_13785	58046910	0
56343058	005_1_13022	56343058	0		008_3_13362	58002538	0		013_0_13845	58046910	0
	005_2_13039	56343058	0		008_4_13416	58002538	0	58046912	012_0_13785	58046912	0
56343106	02A_0_13875	56343106	0	58026222	008_2_13308	58026222	0		013_0_13845	58046912	0
56347484	002_0_12722	56347484	0		008_3_13362	58026222	0		013_1_13860	58046912	0
	002_1_12741	56347484	0		008_4_13416	58026222	0	58046913	012_0_13785	58046913	0
	002_3_12779	56347484	0	58042167	008_2_13308	58042167	0		013_0_13845	58046913	0
56349782	002_0_12722	56349782	0		008_3_13362	58042167	0		013_1_13860	58046913	0
	002_1_12741	56349782	0		008_4_13416	58042167	0	58047712	008_2_13308	58047712	0
	002_3_12779	56349782	0	58042202	008_2_13308	58042202	0		008_3_13362	58047712	0
56356165	002_3_12779	56356165	0		008_3_13362	58042202	0		008_4_13416	58047712	0
56356251	002_2_12761	56356251	0		008_4_13416	58042202	0	58048000	008_2_13308	58048000	0
	002_3_12779	56356251	0	58043053	03A_0_13890	58043053	0		008_3_13362	58048000	0
56356328	04A_0_14000	56356328	0		03A_1_13913	58043053	0		008_4_13416	58048000	0
	04A_1_14034	56356328	0	58043086	04A_0_14000	58043086	0	58048002	008_2_13308	58048002	0
56356329	04A_0_14000	56356329	0		04A_1_14034	58043086	0	58048005	008_2_13308	58048005	0
	04A_1_14034	56356329	0	58043110	02A_0_13875	58043110	0		008_3_13362	58048005	0
56356330	04A_0_14000	56356330	0	58043117	03A_0_13890	58043117	0		008_4_13416	58048005	0
	04A_1_14034	56356330	0		03A_1_13913	58043117	0	58048009	008_2_13308	58048009	0
56356331	04A_0_14000	56356331	0	58043129	02A_0_13875	58043129	0		008_3_13362	58048009	0



SPARE PARTS INSTANCE INDEX

Code	Parts Table	Pos.	Q.ty	Code	Parts Table	Pos.	Q.ty	Code	Parts Table	Pos.	Q.ty
58048009	008_4_13416	58048009	0	58052034	012_2_13824	58052034	0	58057263	008_3_13362	58057263	0
58050345	008_2_13308	58050345	0	58052144	012_1_13807	58052144	0		008_4_13416	58057263	0
	008_3_13362	58050345	0		012_2_13824	58052144	0	58057289	008_2_13308	58057289	0
58051670	008_2_13308	58051670	0	58052145	012_1_13807	58052145	0		008_3_13362	58057289	0
	008_3_13362	58051670	0		012_2_13824	58052145	0		008_4_13416	58057289	0
	008_4_13416	58051670	0	58052146	012_1_13807	58052146	0	58057293	008_2_13308	58057293	0
58052018	012_0_13785	58052018	0		012_2_13824	58052146	0	58057294	008_2_13308	58057294	0
	012_1_13807	58052018	0	58052147	012_1_13807	58052147	0		008_3_13362	58057294	0
	012_2_13824	58052018	0		012_2_13824	58052147	0		008_4_13416	58057294	0
58052019	012_0_13785	58052019	0	58052148	012_1_13807	58052148	0	58057295	008_2_13308	58057295	0
	012_1_13807	58052019	0		012_2_13824	58052148	0		008_3_13362	58057295	0
	012_2_13824	58052019	0	58052149	012_1_13807	58052149	0		008_4_13416	58057295	0
58052020	012_0_13785	58052020	0		012_2_13824	58052149	0	58057302	008_2_13308	58057302	0
	012_1_13807	58052020	0	58052150	012_2_13824	58052150	0		008_3_13362	58057302	0
	012_2_13824	58052020	0	58052151	012_2_13824	58052151	0		008_4_13416	58057302	0
58052021	012_0_13785	58052021	0	58052154	012_2_13824	58052154	0	58057306	008_2_13308	58057306	0
	012_1_13807	58052021	0	58052155	012_2_13824	58052155	0		008_3_13362	58057306	0
	012_2_13824	58052021	0	58052274	011_3_13744	58052274	0		008_4_13416	58057306	0
58052022	012_0_13785	58052022	0	58052304	008_2_13308	58052304	0	58057333	008_2_13308	58057333	0
	012_1_13807	58052022	0		008_3_13362	58052304	0		008_3_13362	58057333	0
	012_2_13824	58052022	0	58052325	011_3_13744	58052325	0		008_4_13416	58057333	0
58052023	012_0_13785	58052023	0	58052326	011_3_13744	58052326	0	58057334	008_2_13308	58057334	0
	012_1_13807	58052023	0	58052327	011_3_13744	58052327	0		008_3_13362	58057334	0
	012_2_13824	58052023	0	58056391	04A_0_14000	58056391	0		008_4_13416	58057334	0
58052024	012_0_13785	58052024	0		04A_1_14034	58056391	0	58057385	001_4_12698	58057385	0
	012_1_13807	58052024	0	58056593	008_4_13416	58056593	0	58057402	008_4_13416	58057402	0
	012_2_13824	58052024	0	58056942	007_2_13157	58056942	0	58057676	013_0_13845	58057676	0
58052029	012_1_13807	58052029	0		007_3_13177	58056942	0		013_1_13860	58057676	0
	012_2_13824	58052029	0	58056991	001_3_12676	58056991	0	58057678	012_0_13785	58057678	0
58052033	012_0_13785	58052033	0		001_4_12698	58056991	0		013_0_13845	58057678	0
	012_1_13807	58052033	0	58057247	009_2_13534	58057247	0		013_1_13860	58057678	0
	012_2_13824	58052033	0		009_3_13564	58057247	0	58057698	009_2_13534	58057698	0
58052034	012_0_13785	58052034	0		009_4_13594	58057247	0		009_3_13564	58057698	0
	012_1_13807	58052034	0	58057263	008_2_13308	58057263	0		012_0_13785	58057698	0



SPARE PARTS INSTANCE INDEX

Code	Parts Table	Pos.	Q.ty	Code	Parts Table	Pos.	Q.ty	Code	Parts Table	Pos.	Q.ty
58057698	013_0_13845	58057698	0	59047709	008_2_13308	59047709	0	59056989	009_4_13594	59056989	0
	013_1_13860	58057698	0		008_3_13362	59047709	0	59057076	008_2_13308	59057076	0
58057712	012_0_13785	58057712	0		008_4_13416	59047709	0		008_3_13362	59057076	0
	013_0_13845	58057712	0	59047743	011_3_13744	59047743	0		008_4_13416	59057076	0
	013_1_13860	58057712	0	59047745	011_3_13744	59047745	0	59057077	008_2_13308	59057077	0
58057714	009_2_13534	58057714	0	59047927	001_2_12649	59047927	0		008_3_13362	59057077	0
	009_3_13564	58057714	0		001_3_12676	59047927	0		008_4_13416	59057077	0
58057722	012_0_13785	58057722	0		001_4_12698	59047927	0	59057240	009_2_13534	59057240	0
	013_0_13845	58057722	0	59048102	02A_0_13875	59048102	0		009_3_13564	59057240	0
	013_1_13860	58057722	0	59056051	001_2_12649	59056051	0		009_4_13594	59057240	0
58057724	012_0_13785	58057724	0		001_3_12676	59056051	0	59057252	009_2_13534	59057252	0
	013_0_13845	58057724	0		001_4_12698	59056051	0		009_3_13564	59057252	0
	013_1_13860	58057724	0	59056052	001_2_12649	59056052	0		009_4_13594	59057252	0
58057732	013_0_13845	58057732	0	59056089	001_3_12676	59056089	0	59057270	009_2_13534	59057270	0
	013_1_13860	58057732	0		001_4_12698	59056089	0		009_3_13564	59057270	0
58057767	013_1_13860	58057767	0	59056111	001_3_12676	59056111	0		009_4_13594	59057270	0
58057768	013_1_13860	58057768	0		001_4_12698	59056111	0	59057308	009_2_13534	59057308	0
58057770	013_1_13860	58057770	0	59056378	04A_0_14000	59056378	0		009_3_13564	59057308	0
58057771	013_1_13860	58057771	0		04A_1_14034	59056378	0		009_4_13594	59057308	0
58057772	013_1_13860	58057772	0	59056935	007_2_13157	59056935	0	59057309	009_2_13534	59057309	0
58150313	008_2_13308	58150313	0		007_3_13177	59056935	0		009_3_13564	59057309	0
	008_3_13362	58150313	0	59056975	009_2_13534	59056975	0		009_4_13594	59057309	0
	008_4_13416	58150313	0		009_3_13564	59056975	0	59059551	011_3_13744	59059551	0
58157346	008_3_13362	58157346	0		009_4_13594	59056975	0	59059561	011_3_13744	59059561	0
	008_4_13416	58157346	0	59056980	007_2_13157	59056980	0	59059571	011_3_13744	59059571	0
59015425	03A_0_13890	59015425	0		007_3_13177	59056980	0	59247884	002_0_12722	59247884	0
	03A_1_13913	59015425	0	59056982	001_2_12649	59056982	0		002_1_12741	59247884	0
59043063	005_1_13022	59043063	0		001_3_12676	59056982	0		002_2_12761	59247884	0
	005_2_13039	59043063	0		001_4_12698	59056982	0		002_3_12779	59247884	0
59047450	001_2_12649	59047450	0	59056984	001_2_12649	59056984	0	59247970	002_0_12722	59247970	0
	001_3_12676	59047450	0	59056986	001_2_12649	59056986	0		002_1_12741	59247970	0
	001_4_12698	59047450	0		001_4_12698	59056986	0	59247971	002_0_12722	59247971	0
59047454	001_2_12649	59047454	0	59056989	009_2_13534	59056989	0		002_1_12741	59247971	0
	001_3_12676	59047454	0		009_3_13564	59056989	0		002_2_12761	59247971	0



SPARE PARTS INSTANCE INDEX

Code	Parts Table	Pos.	Q.ty
59247971	002_3_12779	59247971	0
59248106	02A_0_13875	59248106	0
59256252	002_2_12761	59256252	0
59256257	002_3_12779	59256257	0
59256265	002_3_12779	59256265	0
59259555	011_3_13744	59259555	0
59259563	011_3_13744	59259563	0
59259567	011_3_13744	59259567	0
59259578	011_3_13744	59259578	0
59259580	011_3_13744	59259580	0
92243685	011_3_13744	92243685	0
92457794	011_3_13744	92457794	0